

# Owner Instructions



Original Instructions

Warning! Read instructions before using the machine

LoLine  
NLL 332  
NLL 415





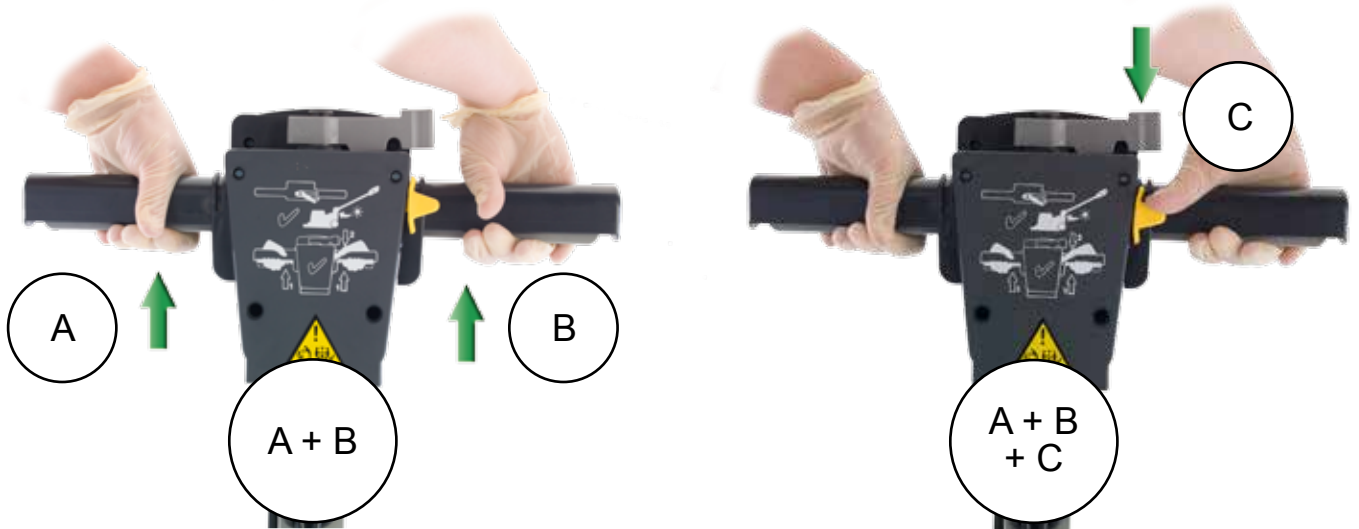

**Auto - Stop**

30 mins



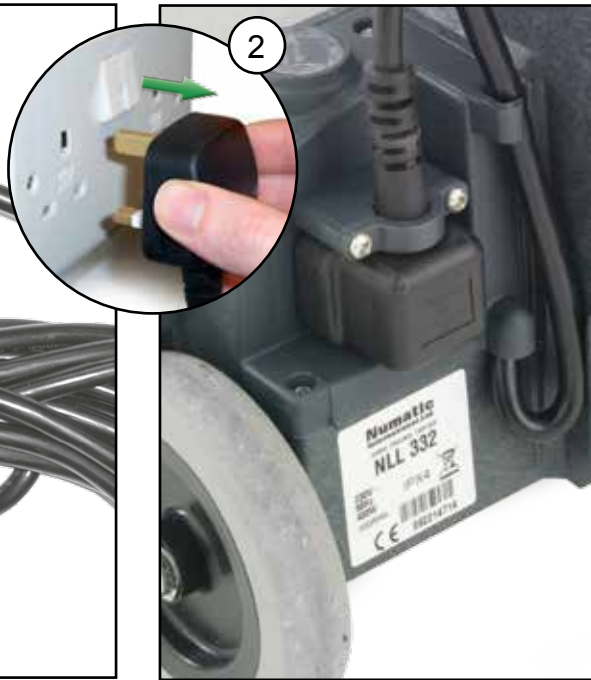
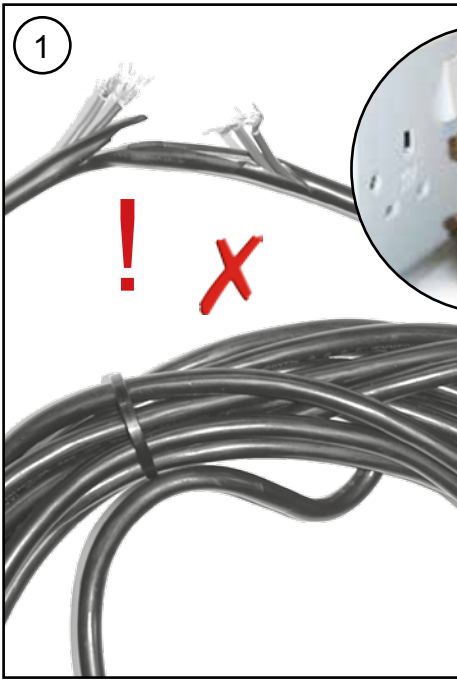

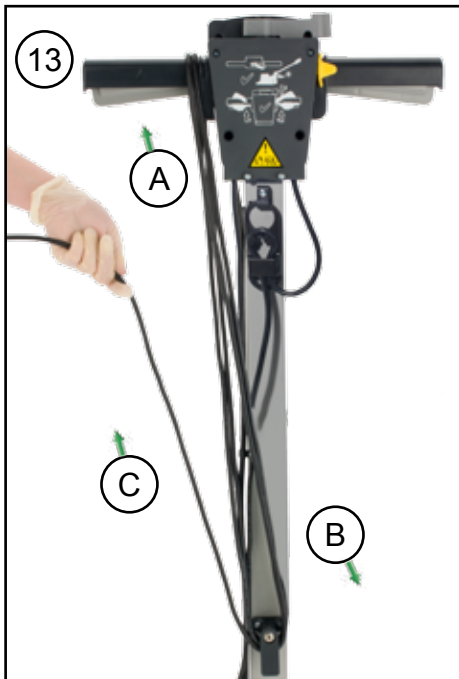



# Optional extra (FMA - 606101) NLL Solution Tank





## Dimensions

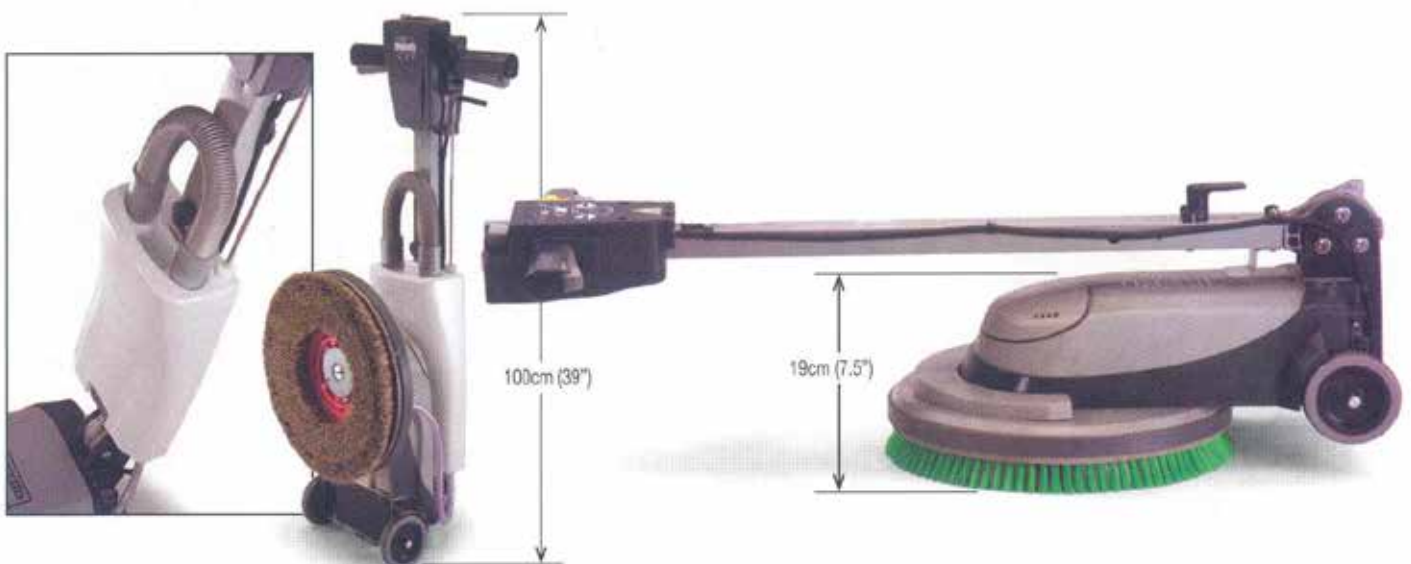



# Rating Label

Company Name  
and Address

**Numatic International. Ltd**  
CHARD, ENGLAND, TA20 2GB

**NLL 332**

230V~  
50 Hz  
400W

IPX 4

25.4Kg

CE Mark

Barcode: 094709460

Machine Description

WEEE Logo

Weight

Machine yr/wk/  
serial number

## Safety Critical Components

### Mains Lead

HO5VV-F x 15M x 3 x 1.0 mm<sup>2</sup>

Floor Machine, accessories and packaging should be sorted for environmentally - friendly recycling



### Only for EU countries:

Do not dispose of Floor Machine into household waste!  
According to the European Directive 2002/96/EC on Waste Electrical and Electronic Equipment and its incorporation into national law. Floor Machine that are no longer suitable for use must be separately collected and sent for recovery in an environmentally - friendly manner.

**PPE**  
(personal protective equipment)  
that may be required for certain operations.



Safety Footwear



Hat Protection



Hi Viz Jacket



Ear Protection



Safety Gloves



Dust / Allergens Protection



Eye Protection



Protective Clothing



Caution Floorsign

### NOTE:

A risk assessment should be conducted to decide what PPE should be worn.





ORIGINAL INSTRUCTIONS  
READ MANUAL BEFORE USE

# Information for Floor Machines

## CAUTION:

Read the instruction manual before using the appliance

## NOTE:

This Product meets the requirements of BS EN 60335 - 2-67

This Machine is also suitable for commercial use, for example in hotels, schools, hospitals, factories, shops, rental businesses and offices for other the normal housekeeping purposes.

Care should be taken in the choice of chemicals, detergents and other liquids. Consult your supplier.

This appliance is not intended for use by persons (including children) with reduced physical sensory or mental capabilities, or lack of experience and knowledge.

## Do's and Don'ts:

- DO Ensure only competent persons unpack/ assemble the machine.
- DO Keep your machine clean.
- DO Keep your brushes in good condition.
- DO Replace any worn or damaged parts immediately.
- DO Daily examine the mains lead for damage, such as cracking or aging. If damaged is found, replace the lead before further use.
- DO Only replace the mains lead with the correct Numatic approved replacement part.
- DO Ensure that the work area is clear of obstructions and/ or people.
- DO Ensure that the working area is well illuminated.
- DO Pre - sweep the area to be cleaned.
  
- DON'T Use steam cleaners or pressure washers to clean the machine or use in the rain.
- DON'T attempt machine maintenance or cleaning unless the power plug has been removed from the supply outlet.
- DON'T Allow any inexperienced repairs. Contact your nearest service centre.
- DON'T Strain the mains lead or try to unplug by pulling on the mains lead.
- DON'T Leave the brush deck in the lowered position when not in use.
- DON'T Expect the machine to provide trouble free, reliable operation unless maintained correctly.
- DON'T Run the machine over any power cables during operation.
- DON'T Leave your machine standing on brush, pads or drive boards when not in use.

## WARNING:

Operators shall be adequately instructed on the use of this machine.

This machine shall be disconnected from its power source (Remove plug from socket outlet.) During cleaning or maintenance or in the event of an accident and when replacing parts or converting the machine to another function.

This machine is not suitable for picking up hazardous dust.

Do not allow supply cord to come into contact with the rotating brushes or pads

As with all electrical equipment care and attention must be exercised at all times during its use, in addition to ensuring that routine and preventive maintenance is carried out

Periodically in order to ensure its safe operation. Failure to carry out maintenance as necessary, including the replacement of parts to the correct standard could render the equipment unsafe and the manufacturer can accept no responsibility or liability in this respect.

When ordering spare parts always quote the model number / serial number specified on the rating plate.

This machine is for indoor use only.

The machine is not to be used or stored outdoors or in wet conditions.

Don't allow the machine to be used by inexperienced or unauthorised operators or without appropriate training.

Only use brushes provided with the appliance or those specified in the instruction manual.

The use of other brushes may impair safety.

A full range of brushes and accessories are available for this product.

Only use brushes or pads which are suitable for the correct operation of the machine for the specific task being performed.

It is essential that this equipment is correct assembled and operated in accordance with current safety regulations. When using the equipment always ensure that all necessary precautions are taken to guarantee the safety of the operator and any other persons who may be affected.

# Hazardous regulation information / Data.



Under certain uses, this machine may be subject to the Provision and Use of Work Equipment Regulations (council directive 89/655/EEC), Control of Substances Hazardous to Health

Regulations, Dangerous Substances and Explosive Atmospheres Regulations and other Safety Regulations (council directive 98/24/EC & 99/92/EC). User must ensure that their use of this machine for any purpose meets these requirements.





Regular inspection and maintenance of this machine in accordance with the manufacturer's recommendations and the above Regulations is essential for its functional and safe operation.

| Model   | Motor | Speed  | Brush | Pad   | Range | Weight  | Sound Pressure dB(A)@1.7M | HAV M/S <sup>2</sup> | Dimensions     |
|---------|-------|--------|-------|-------|-------|---------|---------------------------|----------------------|----------------|
| NLL 332 | 400W  | 200rpm | 330mm | 330mm | 32m   | 18 kg   | 66.6                      | 2.1                  | 1185x580x450mm |
| NLL 415 | 400W  | 150rpm | 400mm | 360mm | 32m   | 18.5 kg | 63.1                      | 1.0                  | 1185x580x450mm |



HAV = Hand Arm Vibration (uncertainty +/- 0.05ms<sup>2</sup>)

## LoLine NLL 332 Accessories - 330mm



|   |   |   |   |
|---|---|---|---|
| <br>FMA 606104  | 330mm<br>Union Mix Polish Brush<br>4- 5 | <br>FMA 606033 | 330mm<br>Polyscrub Brush<br>1                       |
| <br>FMA 606556 | 330mm<br>Nyloscrub Brush<br>1           | <br>606111    | 330mm<br>Nuloc Pad Drive Board<br>1 - 2 - 3 - 4 - 5 |

## LoLine NLL 415 Accessories - 400mm

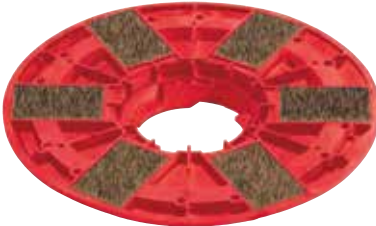
|   |  |  |   |
|---|--|--|---|
| <br>606102 | 400mm<br>Union Mix Polish Brush<br>4 - 5 | <br>606105 | 400mm<br>Polyscrub Brush<br>1                       |
| <br>606108 | 400mm<br>Nyloscrub Brush<br>1            | <br>606112 | 360mm<br>Nuloc Pad Drive Board<br>1 - 2 - 3 - 4 - 5 |

LoLine Floor Machine Application Chart

**NLL 332**

| Wet Scrubbing<br>1 | Spray Cleaning<br>2 | Light Spray Buffing<br>3 | Low Gloss Polish<br>4 | Medium Gloss Polish<br>5 |
|--------------------|---------------------|--------------------------|-----------------------|--------------------------|
| <b>O</b>           | <b>O</b>            | <b>O</b>                 | <b>O</b>              | <b>O</b>                 |

**NLL - 415**







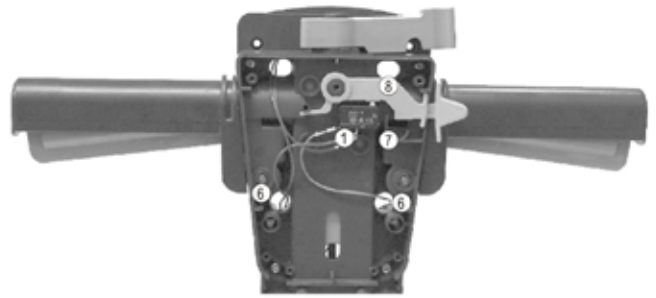
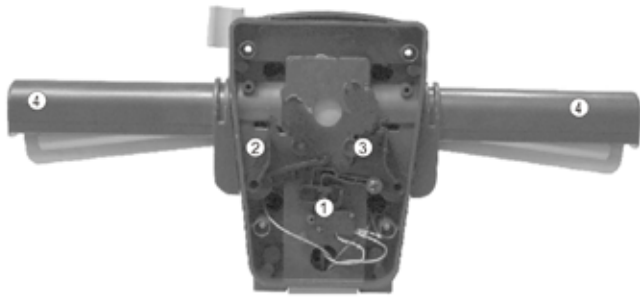

**NLL 415**

| Wet Scrubbing<br>1 | Spray Cleaning<br>2 | Light Spray Buffing<br>3 | Low Gloss Polish<br>4 | Medium Gloss Polish<br>5 |
|--------------------|---------------------|--------------------------|-----------------------|--------------------------|
| <b>O</b>           | <b>X</b>            | <b>X</b>                 | <b>O</b>              | <b>X</b>                 |



















# NLL 332 / NLL 415 Floorcare Accessories



| Part No.   | Description.                  | Part No.  | Description.     |
|--|-------------------------------|---|------------------|
|  1. 229483  | SNAP ACTION SWITCH            |  5. 227581  | TRIGGER MOULDING |
|  2. 227586  | RH OPERATING LEVER            |  6. 219803  | TRIGGER SPRING   |
|  3. 227585  | LH OPERATING LEVER            |  7. 227584  | SWITCH LEVER     |
|  4. 227580 | HANDLE MOULDING               |  8. 227583 | ADJUSTMENT LEVER |
|  | 219804 SWITCH SPRING          |   |                  |
|  | 219805 4MM SPIREFIX           |   |                  |
|  | 227587 CENTRE SWITCH MOULDING |   |                  |



|   |                                |   |                    |
|---|--------------------------------|---|--------------------|
|  1. 229081 | HANDLE CASTING                 |  7. 229030                             | ANTI VIBRATION PAD |
|  2. 229482 | ADJUSTMENT GEAR (DUAL SETTING) |  (NOT SHOWN)<br>227582 HANDLE END PLUG |                    |
|  3. 229073 | GEAR LOCKING PIN               |   |                    |
|  4. 229138 | GEAR LOCKING SPRING            |   |                    |
|  5. 429096 | HANDLE PAINTED                 |   |                    |
|   |                                |  6. 229484                            | HANDLE LOCKING ROD |

|  |                           |   |                                    |
|--|---------------------------|---|------------------------------------|
|  206575 | 230V DC RELAY             |  8. 236071 | 15.0MT x1.0MMx 3CORE CABLE (UK).   |
|  205285 | 10 uf MOTOR RUN CAPACITOR |  236099    | 15.0MT x1.0MMx 3CORE CABLE (EURO). |
|  229454 | HANDLE SWITCH             |  219345    | EXTERNAL CIRCLIP                   |
|  |                           |  219891    | WAVE WASHER                        |
|  |                           |  329112  | GREY WHEEL                         |
|  |                           |  206723    | AXLE                               |

# NLL 332 / NLL 415 (Floor Machine)

WD - 0341 (A08) 03.06.10

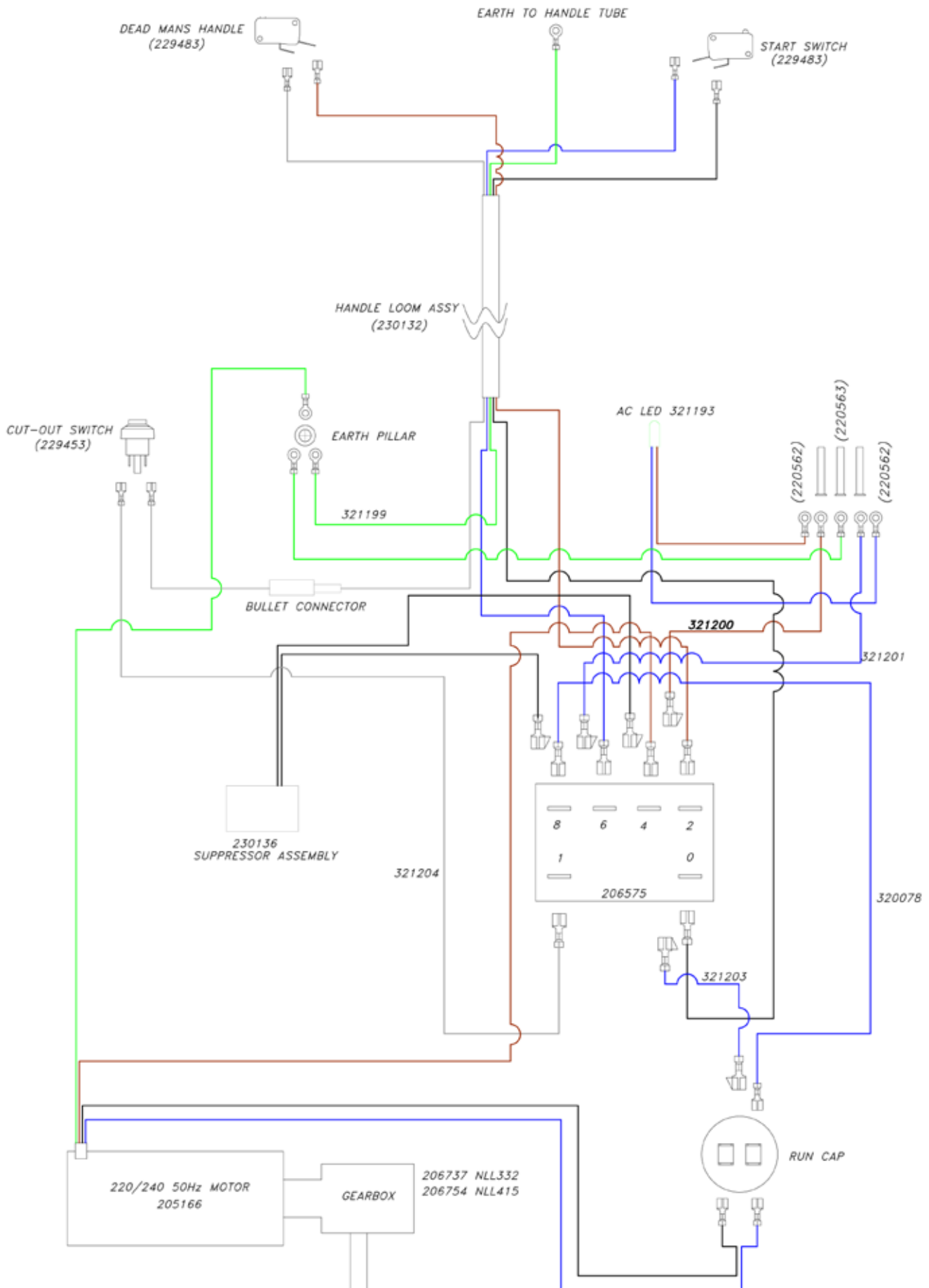

# **Numatic International** *Warranty*

**Numatic International Limited warrant to the original purchaser that its products are free of defects in both material or workmanship for the period shown below:-**

|   |                            |
|---|----------------------------|
| <b>Homecare and Cleancare Vacuum cleaners.....</b>          | <b>2 Years</b>             |
| <b>Rotary Floor Machines.....</b>                           | <b>2 Years</b>             |
| <b>Twintec Auto Scrubber Dryer.....</b>                     | <b>1 Year</b>              |
| <b>Vario Ride-On Scrubber Dryer.....</b>                    | <b>1 Year / 1500 hours</b> |
| <b>Mopping, Compacts, Combi and Servocare Products.....</b> | <b>1 Year</b>              |
| <b>Individual Accessories and Spare Parts.....</b>          | <b>6 Months</b>            |

Note: This warranty expressly excludes consumable parts such as carbon brushes, floor brushes, mops, batteries etc, that are considered replaceable from time to time during the normal working life of the machine.

- A. The warranty period commences from the date the goods are purchased.
- B. All warranty claims must be processed through the Dealer from whom the equipment was purchased. The Dealer will co-operate with the purchaser throughout the warranty claims procedure and will arrange any necessary repairs using genuine Numatic parts.
- C. If the original Dealer is no longer able to fulfil his obligations please contact Numatic International Limited with full details of the claim and proof of purchase so that this may be processed without delay.
- D. Any warranty claim can only relate to the specific part that is proven to be at fault and for which a replacement will be supplied but cannot be extended to constitute a claim against the complete machine.
- E. Numatic International will supply the Dealer with any warranty parts required, subject to the claim being validated, after return of the faulty items in accordance with Numatic International Limited's General Conditions of Sale.
- F. Claims will not be accepted if they are the result of fair wear and tear, misuse or abuse of any kind.
- G. No replacement will be given unless the appropriate evidence of the validity of the claim has been provided to the satisfaction of Numatic International Limited.
- H. Numatic International Limited reserve the right to charge for any unnecessary work carried out as a result of an invalid claim.
- I. No variation to this warranty may be made or implied by any member of Numatic International Limited or its Dealers unless such variation is in writing and authorised by the Company



**Numatic International Limited. Chard, Somerset, TA20 2GB**  
**Telephone: 01460 68600 Fax: 01460 68458**

© Numatic International Limited



# EU Declaration of Conformity

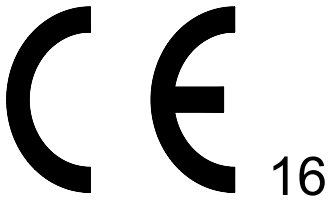

## EU DECLARATION OF CONFORMITY

We hereby declare under our sole responsibility that the following equipment fulfils all the relevant provisions of the following EU Directives:

Machinery Directive 2006/42/EC  
EMC Directive 2014/30/EU  
RoHS Directive 2011/65/EU

**Machine Description:**  
**Type: NLL series**

**Floor Machine**

**Manufactured by: Numatic International Limited**

Relevant standards upon which conformity is declared include:

IEC 60335-1 2001 + A1 2004 + A2 2006 + National  
Deviations  
IEC 60335-2.67 2002 + A1 2004

EN 55014-1:2006  
EN55014-2:1997+A1  
EN61000-3-2:2006  
EN61000-3-3:1995+A1+A2  
BS EN 50366:2003

A technical construction file for this equipment is retained at the manufacturer's address under the authorisation of the following signatory:

**Name: Allyn Boyes**

**Position: Technical Manager**

Signed:

Date: 20/04/2016



Numatic International Limited,  
Chard, Somerset.  
TA20 2GB  
www.numatic.co.uk

**GB**

# LoLine



DISTRIBUTED BY

Parish-Supply.com  
Syracuse, NY 315-433-9031  
[www.parish-supply.com](http://www.parish-supply.com)

