

Parish-Supply.com
 Syracuse, NY 315-433-9031
 www.parish-supply.com



BILLY GOAT QV PUSH VACUUM

Owner's Manual

QV550, QV550H

Accessories

VACUUM HOSE KIT	DEBRIS BAG SKIRT	PARKING BRAKE
5" (127mm) x 10' (3m) collapsible hose for vacuuming in hard-to-reach areas	Directs dust away from the operator.	Locks the rear wheels to prevent freewheeling.
P/N 831018	P/N 831268	P/N 831609

Debris bags and Filter

STANDARD DEBRIS BAG	HOOD FILTER	DEBRIS AND DUST SOCK
Standard on QV models. For dusty conditions.	Filters out dust from vacuum exhaust.	Traps dust keeping it away from the operator.
P/N 831225	P/N 831226	P/N 831267



CONTENTS

SPECIFICATIONS AND SOUND/VIBRATION	3
INSTRUCTION LABELS	4
PACKING CHECKLIST AND ASSEMBLY	5
OPERATION AND BAG CARE	6-7
MAINTENANCE AND TROUBLESHOOTING	8
ILLUSTRATED PARTS & PART LISTS	9-12



Specifications

	QV550	QV550H
HP	5.5 (4.1 kW)	5.5 (4.1 kW)
Engine: Type	12H1320118B8	GX160T1QX2
Engine: Fuel Capacity	3.0 qt. (2.84 L)	3.88 qt. (3.6 L)
Engine: Oil Capacity	0.66 qt. (0.62 L)	0.69 qt. (0.65 L)
Total Unit Weight:	180# (81.6 kg)	175# (73.4 kg)
Overall Length	63" (1.6m)	63" (1.6m)
Overall Width	33" (0.84m)	33" (0.84m)
Overall Height	51" (1.3 m)	51" (1.3 m)
Max. operating slope	20 ⁰	20 ⁰
Sound at operators ear	77 dBa	77 dBa
In accordance with 2000/14/EEC	97 dBa	97 dBa
Vibration at operator position	0.47g (4.64m/s ²)	0.47g (4.64m/s ²)

SOUND



SOUND LEVEL 77 dB(a) at Operator Position

Sound tests were conducted in accordance with 2000/14/EEC, and were performed on 3-28-12 under the conditions listed below.

Sound power level listed is the highest value for any model covered in this manual. Please refer to serial plate on the unit for the sound power level for your model.

General Conditions:	Sunny
Temperature:	61°F (16°C)
Wind Speed:	6 mph (10 kmh)
Wind Direction:	East North East
Humidity:	86%
Barometric Pressure:	30.01"Hg (762 mm Hg)

VIBRATION DATA

VIBRATION LEVEL 0.47g (4.64m/s²)

Vibration levels at the operator's handles were measured in the vertical, lateral and longitudinal directions using calibrated vibration test equipment. Tests were performed on 3-29-12 under the conditions listed below.

General Conditions:	Sunny
Temperature:	57°F (14°C)
Wind Speed:	16 mph (25.7kph)
Wind Direction:	East
Humidity:	89%
Barometric Pressure:	29.9Hg (101.3kpa)

INSTRUCTION LABELS

The labels shown below were installed on your BILLY GOAT® QV Vacuum. If any labels are damaged or missing, replace them before operating this equipment. Item numbers from the Illustrated Parts List and part numbers are provided for convenience in ordering replacement labels. The correct position for each label may be determined by referring to the Figure and Item numbers shown.

LABEL WARNING
ITEM #35 P/N 831265



LABEL THROTTLE
ITEM #104 P/N 810656



INSTRUCTION LABEL
ITEM # 37 P/N 831259

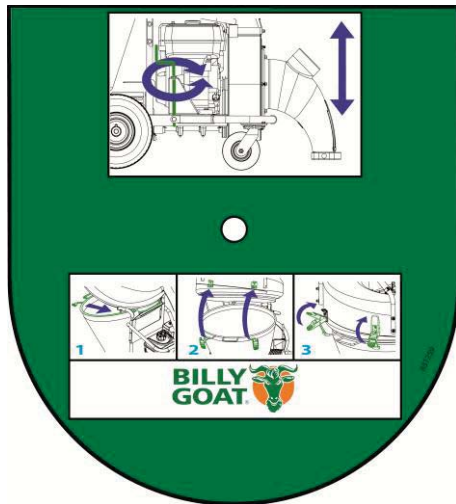

ENGINE LABELS

HONDA

■ READ OWNERS MANUALS BEFORE OPERATION.
 ■ LIRE LE MANUEL D'UTILISATEUR AVANT USAGE.
 ■ VOR INBETRIEBNAHME UNBEDINGT
 BEDIENUNGSANLEITUNG DURCHLESEN.
 ■ NO UTILIZAR SIN ANTES NO HABER LEIDO EL MANUAL.



OIL ALERT

■ WHEN OIL LEVEL LOW,
ENGINE STOPS IMMEDIATELY.

BRIGGS & STRATTON

WARNING

Read and follow Operating Instructions before running engine.

Gasoline is flammable. Allow engine to cool at least 2 minutes before fueling.

Engines emit carbon monoxide, DO NOT run in enclosed area.

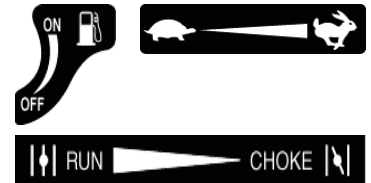



PACKING CHECKLIST

Your Billy Goat is shipped from the factory in one carton, completely assembled except for the nozzle.



READ all safety instructions before assembling unit.
TAKE CAUTION when removing the unit from the box



PUT OIL IN ENGINE BEFORE STARTING

PARTS BAG & LITERATURE ASSY

Warranty card P/N- 400972, Operator's Manual P/N-831504, Declaration of Conformity P/N-831503.
General Safety and Warnings Manual P/N-100294

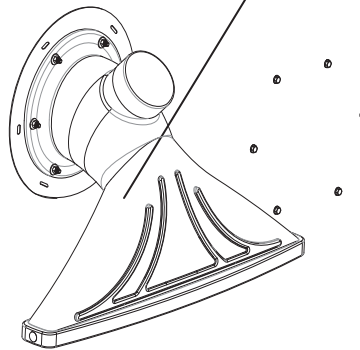
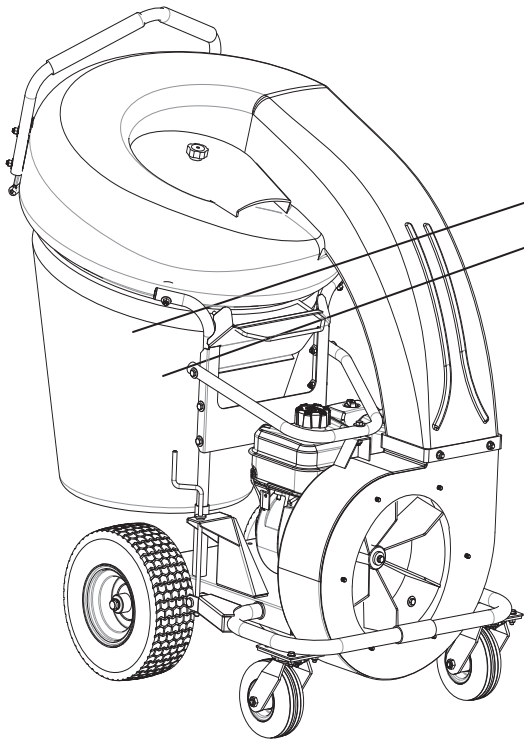

- Boxing Parts Checklist**
- Debris Bag P/N-831225
 - Dust Sock P/N-831268
 - Front Nozzle P/N-831606
 - Literature Assy P/N-831021
 - Briggs & Stratton 5.5 HP
 - Honda 5 HP

ASSEMBLY

1. Remove the unit from the box. Be careful as not to damage the unit.
2. Attach the front nozzle (item 7) to the housing and secure it with the lock nuts (item 45) and washers (item 49) located in the parts bag.





OPERATION

VACUUMING OPERATION

VACUUM NOZZLE HEIGHT ADJUSTMENT: Is adjusted by turning the knob clockwise increases height and counter-clockwise to lower it. Adjust nozzle height according to surface conditions and debris size; For vacuuming on flat surfaces, set nozzle 1/2" (12.7 mm) to 5/8" (15.8 mm) above ground; Higher for uneven terrain and turf.

FOR MAXIMUM PICKUP: Adjust nozzle close to debris, but without blocking airflow into the nozzle.

NOTE: Never bury nozzle into debris.

  **CLEARING A CLOGGED NOZZLE & EXHAUST:** Turn engine off and wait for impeller to stop completely and disconnect spark plug wire. Wearing durable gloves, remove clog, this may require removing the front nozzle. **Danger**, the clog may contain sharp materials. Reconnect spark plug wire.

DEBRIS BAG

Debris bags are normal replaceable wear items.

Note: *Frequently empty debris to prevent bag overloading with more weight than you can lift.*
Use the dust skirt when debris will be vacuumed in dusty conditions.

DO NOT place bag on or near hot surface, such as engine. Run engine at 1/2 throttle for first 1/2 hour to condition new bag. Your new bag requires a break-in period to condition the pores of the material against premature blockage. The entire bag surface serves as a filter, and must be able to breathe to have good vacuum performance. Be sure engine has come to a complete stop before removing or emptying bag.

HOOD FILTER

Hood filters are normal replaceable wear items.

The hood filter is for use in dry dusty conditions only. **DO NOT** get the filter wet. Clean with light compressed air only.

DUST SOCK

Dust Skirts are normal replaceable wear items.

See next page for Dust sock care.

This vacuum is designed for picking up trash, organic material and other similar debris.

However, many vacuums are used where dust is mixed with trash. Your unit can intermittently vacuum in dusty areas. Dust is the greatest cause of lost vacuum performance. However, following these rules will help maintain your machine's ability to vacuum in dusty conditions:

- Run machine at idle to quarter throttle.
- The debris bag must be cleaned more frequently. A vacuum with a clean, pillow soft bag will have good pickup performance. One with a dirty, tight bag will have poor pickup performance. If dirty, empty debris and vigorously shake bag free of dust. *Having one or more spare debris bags is a good way to reduce down time while dirty bags are being cleaned.*
- DO NOT** leave debris in bag while in storage.



DUST SOCK CARE AND MAINTENANCE

Purpose:

The dust sock acts as a secondary filter lowering the amount of dust that escapes the bag.

Dust socks are to be used in dry and dusty conditions ONLY. Using the dust sock in damp or wet conditions may damage the dust sock and decrease the effectiveness of the filter.

The dust sock may be installed by simply attaching the mating Velcro strips between the bag and the dust sock. Over time the dust sock will begin to fill with dust during use. Periodically remove the dust sock, empty the loose dust out and clean the sock. For a light clean, simply shake the sock, for a deep clean, see below. To remove the sock, simply separate the Velcro.



Dust Sock Care Information:



DO NOT STRIKE THE BAG WITH OR AGAINST OBJECTS



DO NOT SNAG THE BAG



LIGHTLY CLEAN WITH COMPRESSED AIR ONLY, FROM THE OUTSIDE IN. KEEP THE NOZZLE 6-12 INCHES FROM FABRIC



DO NOT GET WET

Dust Socks are normal replaceable wear items. Replacement P/N- 831267



QV PUSH Operator's Manual

PERIODIC MAINTENANCE

Periodic maintenance should be performed at the following intervals:

Maintenance Operation	Every Use (daily)	Every 5 hrs (daily)	Every 10 Hrs	Every 25 Hrs	Every 50 Hrs
Inspect for loose, worn or damaged parts.		•			
Clean Debris bag	•				
Check Tire pressure	•			•	
Engine (See Engine Manual)					
Check for excessive vibration		•			
Grease zerks					•

IMPELLER REMOVAL

1. Disconnect spark plug wire.
2. Secure the unit to keep it from moving.
3. Remove the nozzle (item 7) from the housing, then remove the plate it was attached to (item 30).
4. Walk the belt (item 22) off of the lower pulley (item 23) and then slide it off of the impeller groove. If you cannot walk it off of the bottom pulley loosen the bearings (item 24) on the underside this will allow a little more play in the pulley.
5. Slide belt out of belt groove in impeller hub drive pulley.
6. Remove impeller bolt and lock washer.
7. If impeller slides off freely, proceed to (step 12). **(Do not drop impeller).**
8. If impeller does not slide off crankshaft, place two crowbars between impeller and housing on opposite sides. Pry impeller away from engine until it loosens. *Using a penetrating oil can help loosen a stuck impeller.*
9. Slide impeller off of crank shaft and remove impeller from housing.
10. Reinstall new impeller, new impeller bolt and lock washer in reverse order of removal. *(See the parts drawing on pages 9-12 for parts break-down and parts list on page 10 for proper impeller bolt torque specifications.)*
11. When impeller is installed, slide the belt back into the groove on the hub and walk it back onto the bottom pulley. Retighten the bearings if they were loosened.
12. Reattach nozzle plate and nozzle in reverse order of removal.
13. Reconnect spark plug wire.
14. Check for proper operation.

Grease: Wheels, Casters, and Shaft Bearings.

Tire air pressure: Check at regular intervals & maintain: Rear SP 13" tires at **20 psi.** (137.9 kPa).

Troubleshooting

Problem	Possible Cause	Solution
Abnormal vibration.	Loose or out of balance impeller or loose engine	• Check impeller and replace if required. • Check engine
Will not vacuum or has poor vacuum performance	• dirty debris bag. Nozzle height set too high or low. Hose kit cap missing. Clogged nozzle or exhaust. Excessive quantity of debris.	• Clean debris bag. Shake bag clean or wash. Adjust nozzle height. Check for hose kit cap. Unclog nozzle or exhaust. Allow air to feed with debris
Engine will not start.	• Stop switch off. Throttle in off position. Engine not in full choke position. Out of gasoline. Bad or old gasoline. Sparkplug wire disconnected. Dirty air cleaner. Low oil (honda only)	• Check stop switches, throttle, choke position and gasoline. Connect spark plug wire. Clean or replace air filter. Or contact a qualified service person.
Engine is locked, will not pull over.	• Debris locked in impeller. Engine problem.	• See page 6. Contact a engine service dealer for engine problems
Nozzle scrapes ground in lowest height setting.	Nozzle height out of adjustment	Adjust nozzle height (See Nozzle height fine adjustment for hard surfaces on page 6

PARTS DRAWING QV

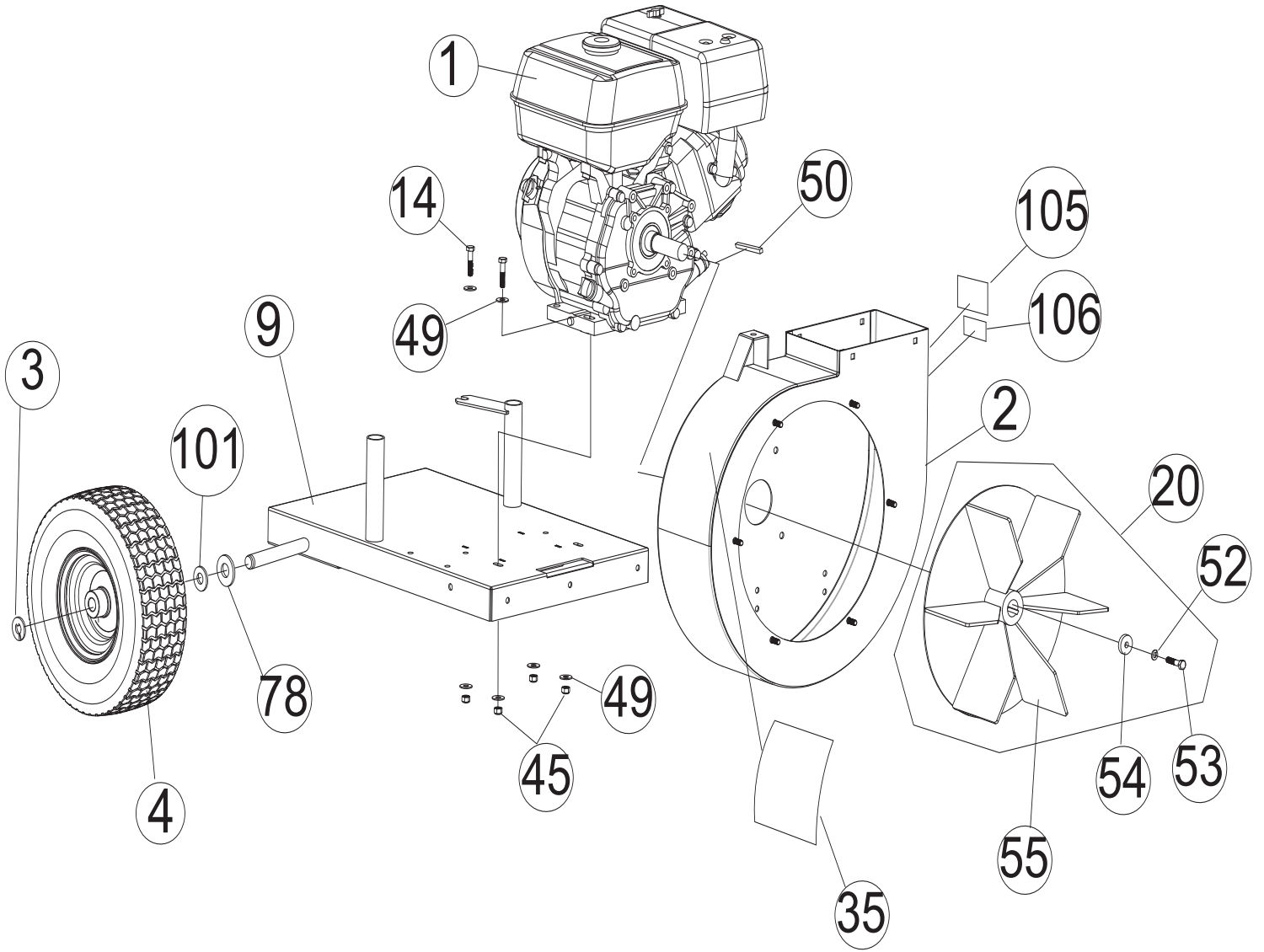



QV PUSH Operator's Manual

ITEM	DESCRIPTION	QV550 PART NO.	QTY	QV550H PART NO.	QTY
1	ENGINE BRIGGS 5.5 HP	350379	1	-	-
	ENGINE HONDA 5.5 OHV GX160	-	-	600115	1
2	HOUSING WA W/LABELS	831600	1	831600	1
3	SNAP RING 3/4	850230	1	850230	1
4	WHEEL 13" X 5" PNEU	831203	2	831203	2
9	ENGINE BASE WA	831105	1	831105	1
14	SCREWCAP 5/16"-18 X 1 1/2" HCS ZP	8041030	4	8041030	4
20	IMPELLER ASSY	831601	1	831601	1
35	LABEL WARNING QV	831265	1	831265	1
45	NUT LOCK 5/16"-18 HEX ZP	8160002	9	8160002	9
49	WASHER 5/16" FLAT	8171003	4	8171003	4
50	KEY 3/16" SQ X 2 1/4"	9201087	1	9201087	1
	KEY 1/4" SQ X 2 1/8	-	-	-	-
52	WASHER LOCK 5/16" SPLIT	8177011	1	8177011	1
53	SCREWCAP 5/16"-24 X 2 1/4" GR.8 W/PATCH	831272	1	831272	1
54	WASHER 1.125 OD X 0.344 ID X 0.25	441150	1	441150	1
55	IMPELLER 5HP WA (torque 17-22 ft.lbs [23-30 N.m])	831104	1	831104	1
78	WASHER 3/4" SAE	8172015	2	8172015	2
101	WASHER .765 ID X 1.25 OD X .06	850238	2	850238	2
105	LABEL MADE IN USA	520116	1	520116	1
106	LABEL PATENT PENDING	500183	1	500183	1

PARTS DRAWING QV

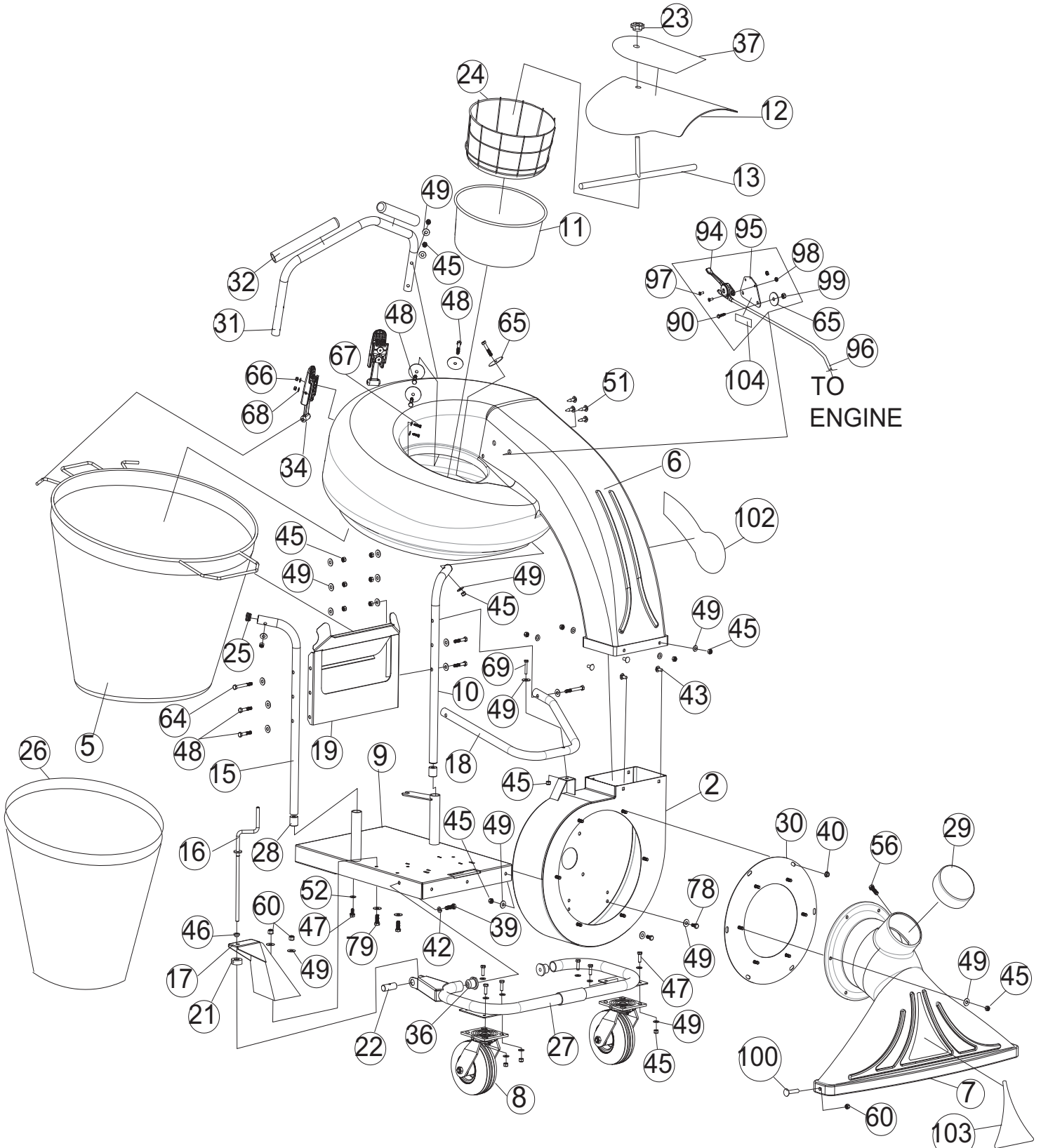



QV PUSH Operator's Manual

PARTS LIST

ITEM	DESCRIPTION	QV550 PART NO.	QTY	QV550H PART NO.	QTY
2	HOUSING QV WA W/LABELS	831600	1	831600	1
5	BAG QV	831225	1	831225	1
6	HOOD QV	831605	1	831605	1
7	NOZZLE 32" W/LABELS	831606	1	831606	1
8	CASTER SWIVEL QV	831201	2	831201	2
9	ENGINE BASE 5 HP WA SP	831105	1	831105	1
10	HANDLE LOWER LFT	831404	1	831404	1
11	HOOD FILTER	831223	1	831223	1
12	HOOD SCOOP QV PUSH W/LABEL	831604	1	831604	1
13	ROD FILTER HOLDER QV	831266	1	831266	1
15	HANDLE LOWER RT	831403	1	831403	1
16	HEIGHT ADJ ROD	831214	1	831214	1
17	HEIGHT ADJ BRACKET WA	831110	1	831110	1
18	HANDLE WISHBONE	831405	1	831405	1
19	BRACKET HANDLE SUPPORT	831222	1	831222	1
21	STOP COLLAR	831216	1	831216	1
22	PIVOT HEIGHT ADJ QV	831209	1	831209	1
23	KNOB 3/8" - 16 SOLID HUB	811230	1	811230	1
24	FILTER FRAME	831223	1	831223	1
25	PLUG TUBE INSERT 1" OD	890132	2	890132	2
26	DUST SOCK	831267	1	831267	1
27	FRAME CASTER QV WA	831108	1	831108	1
28	INSERT 5/16"-18 TUBE 14/16 GA	501243	2	501243	2
29	CAP 5" VINYL BLACK	831211	1	831211	1
30	PLATE NOZZLE WA QV	831109	1	831109	1
31	HANDLE UPPER QV	831406	1	831406	1
32	GRIP 1" OD X 9.5"	430342	2	430342	2
34	BAG LATCH	840016	2	840016	2
36	BUSHING FRAME PIVOT	831207	2	831207	2
37	LABEL INSTRUCTION QV	831258	1	831258	1
39	SCREWCAP 3/8"-16 X 1 1/4" HCS ZP	8041051	2	8041051	2
40	NUT 5/16-18 SER HEX WSHR FLNG ZP	350346	6	350346	6
42	WASHER LOCK 3/8" ST MED	8177012	2	8177012	2
43	BOLT CARRIAGE 5/16"-18 X 3/4" ZP	8024039	4	8024039	4
45	NUT LOCK 5/16"-18 HEX ZP	8160002	33	8160002	33
46	BUSING HEIGHT ADJ BRKT QV	831215	1	831215	1
47	SCREWCAP 5/16"-18 X 1" HCS ZP	8041028	8	8041028	8
48	SCREWCAP 5/16"-18 X 1 3/4" HCS ZP	8041031	10	8041031	10
49	WASHER 5/16" FLAT	8171003	45	8171003	45
51	PLUG SNAP RIVET 0.232 DIA	840114	4	840114	4
52	WASHER LOCK 5/16" SPLIT	8177011	2	8177011	2
56	SCREW PLASTITE 1/4"-20 X 3/4" HWH ZP	840082	1	840082	1
60	NUT LOCK 3/8" -16 HEX	8160003	4	8160003	4
63	WASHER 3/8" FLAT	8171004	5	8171004	5
64	SCREWCAP 5/16"-18 2 3/4" HCS ZP	8041035	2	8041035	2
65	WASHER 2" OD X 0.344 ID X 16 GA	810652	8	810652	8
66	NUT LOCK #10-24 HEX	8155007	4	8155007	4
67	SCREW MACH #10-24 X 3/4"	8059136	4	8059136	4
68	WASHER #10 SAE	8172005	8	8172005	8
69	SCREWCAP 5/16"-18 X 1 1/2"	8041030	1	8041030	1
78	SCREWCAP 5/16"-18 X 3/4" HCS ZP	8041026	4	8041026	4
79	SCREWCAP 3/8"-16 X 1" HCS ZP	8041050	2	8041050	2
90	SCREWCAP 1/4"-20 X 3/4"	8041004	2	8041004	2
94	CONTROL THROTTLE	440012	1	440012	1
95	PLATE THROTTLE	500358	1	500358	1
96	CABLE THROTTLE	440178	1	440178	1
97	SCREW MACH HD PHIL #10-24	830514	2	830514	2
98	NUT LOCK LT #10-24	8164005	2	8164005	2
99	NUT FLANGE 1/4"-20	900453	2	900453	2
100	BOLT CARRIAGE 3/8"-16 X 1"	8024058	2	8024058	2
102	LABEL BADGING QV	831260	2	831260	2
103	LABEL NOZZLE QV	831261	1	831261	1
104	LABEL THROTTLE	810656	1	810656	1