



---

## **Operation & Maintenance Manual**

For Commercial Use Only

---



**SWB 26/8  
Battery Sweeper**



## Long-Term Buyer Protection Limited Warranty

Tornado Industries, Inc. (Tornado) warrants to the end user customer that the Tornado products will be free from defects in material and workmanship for the duration(s) described below. This limited warranty **DOES NOT** cover machines and/or components subject to normal wear and tear, damage that occurs in shipping, failures resulting from modification, accident, unsuitable operating environment, misuse, abuse, neglect or improper maintenance by you. For full details, contact your Authorized Tornado Distributor, Service Center, or the Tornado Technical Service Department. Tornado sales and service representatives are not authorized to waive or alter the terms of this warranty, or to increase the obligations of Tornado under the warranty.

**10 Years\***

*Plastic water tanks and Rotationally-molded bodies*

**2 Years\***

*Parts on all Tornado cleaning equipment*

**1 Year\***

*Labor on all Tornado cleaning equipment*

**1 Year\***

**Warranty on batteries, one year prorated.**

*All battery warranties are handled directly by the battery manufacturer, on a one year prorated basis*

**\*Effective January 1<sup>st</sup>, 2011. Terms subject to change without notice.**

1. Except all Windshear™ Blower-Dryers, Side and Downdraft, Insulation Blowers, CV 30, CV 38, CW 50, CW 100, EB30, CK14/1, CK LW 13/1, CV 38/48 Dual, PV6, PV10 and all chargers are warranted for 1 (one) year for both parts and labor.
2. All-non wear item parts purchased after warranty expiration are warranted for 90 days.
3. Warranty starts from the date of sale to the consumer or, at Tornado's discretion, 6 months after the dealer purchased the unit from Tornado, whichever comes first.
4. The EB 30 is warranted for a period of 90 days for both parts and labor
5. The warranty on engines used on propane powered equipment is limited to motor manufacturer's warranty.
6. Ride on scrubbers are warranted for 24 months parts, 6 months labor or 1,000 hours, whichever occurs first.

*Note: Tornado, The Latest Dirt, Floorkeeper, Carpetkeeper, Carpetrinser, Carpetrinser/Dryer, Headmaster, Taskforce, PAC-VAC, T-Lite, Glazer, Windshear, Max-Vac, and Trot-Mop are trademarks of Tornado Industries*

Website: [www.tornadovac.com](http://www.tornadovac.com)  
Phone 1.800.VACUUMS  
Fax: (630) 818-1301  
Address: 333 Charles Court, Suite 109  
West Chicago, IL 60185

1.800.VACUUMS

60 Years of Cleaning Innovation

A Tergo Company

Form F2662.© 2011. All rights reserved

## Table of content



<b>1 Safety information</b> .....	<b>4</b>
1.1 Safety and Warning Symbols .....	4
1.2 General information .....	4
1.3 Operating information .....	4
1.4 Maintenance information .....	5
1.5 Particular risks .....	5
1.6 Environmental protection.....	6
1.7 Labels on the machine .....	6
<b>2 Starting Up</b> .....	<b>7</b>
2.1 Unpacking and assembling .....	7
2.2 Instruction .....	8
2.3 Initial battery charge .....	8
2.4 Prior to starting up .....	8
2.5 Operation.....	8
2.6 Stopping the machine.....	8
2.7 After completing work.....	9
<b>3 Operation</b> .....	<b>9</b>
3.1 Method of operation .....	9
3.2 Operating and indicator elements .....	10
<b>4 Technical Data</b> .....	<b>11</b>
<b>5 Maintenance and Service</b> .....	<b>12</b>
5.1 Maintenance Plan.....	12
5.2 Battery system.....	13
5.3 Side brushes.....	14
5.4 Rotary brush .....	15
5.5 Debris container .....	16
5.6 Dust vacuum.....	16
<b>EC Declaration of Conformity</b> .....	<b>17</b>

# 1 Safety information

## 1.1 Safety and Warning Symbols

All paragraphs in this manual referring to your personal safety, the safety of your machine and

the environment protection are attributed one of the following warning symbols:

<i>Symbol</i>	<i>Hazardous for</i>	<i>Description</i>
Safety Provisions 	persons and goods	Safety Provisions in dangerous situation caused by misuse inaccurate adherence of instructions or prescribed work routine.
CAUTION 	the machine	Important information on handling the machine in order to maintain operability.
Ecological hazard 	the environment	Due to use of substances representing an inherent danger to health of environment

## 1.2 General information

- In addition to the information provided
- Before starting up the machine for the first time, read the operating manual supplied with it thoroughly as well as any separate manuals provided with additional or attachment devices and observe all the information during work.
- The equipment may only be operated, serviced and repaired by personnel trained in the operation of its use.
- Particular attention should be paid to the information regarding safety. Technical expertise is the key to preventing errors
- when operating the machine and ensuring trouble-free operation.
- The operating manual must always be kept at the operating location of the machine and, as a result, should be kept in a safe place on the equipment.
- The warning labels attached to the machine provided important information concerning safe operation. Illegible or missing labels must be replaced by new ones.
- For reasons of safety, always use original spare parts.

## 1.3 Operating information

- Before starting the machine up for the first time, the battery to be used must be fully charged, properly, by implementing the initial battery charge routine. Please pay attention to the operating manual provided with the charging unit as well as the manual from the battery manufacturer.  
Tornado assumes no liability for damage to
- the battery caused by a fault when the battery is charged for the first time.
- Check the operational safety of the machine each time before starting it up! Clear any faults immediately!
- Before starting work, the operator must be fully familiar with all adjustment, operating and control elements as well as their

respective function! It is too late to do this when the machine is actually in operation!

- Always wear heavy duty, non-slip footwear when working with the machine.
- The machine may only be used on those surfaces which have been approved by the contractor or person appointed by him.
- When using the machine, it is essential to pay attention to third parties, especially children.
- Accelerate the machine immediately after switching on the brush head drive, otherwise imprints of the brush could be produced.

- The machine is not suitable for clearing up hazardous, inflammable or explosive fluids, dust or substances.
- It is forbidden to use the machine in potentially explosive atmospheres.
- The side brush must be raised in order to transport the machine.
- The machine has been conceived for use on level surfaces with a maximum gradient of 2%.

## 1.4 Maintenance information

- Operating personnel must complete the necessary daily and weekly maintenance work. All other maintenance work must be completed at your local Tornado authorized service center.
- The maintenance work and maintenance intervals prescribed in the operating manual must be adhered to.
- Suitable tools must be used for cleaning and maintenance work.
- The machine must be inspected by a recognized technical expert in respect of operational safety, within the terms of the applicable accident prevention laws, at reasonable intervals (we recommend at least once a year) and following modification or repairs.
- Spare parts must comply with the minimum technical requirements stipulated by the manufacturer! This is ensured by the use of original spare parts.

- The machine must be switched off prior to cleaning or servicing it or to replacing parts. The drive bar must be out of operation!
- Always disconnect the battery plug before starting any work on the electrical installation.
- When working in the area of the raised hood, it must be hinged open fully to prevent it being knocked shut or further open and down unintentionally.
- It is not permitted to clean the machine with a pressure washer or steam blaster.
- It is not permitted to use aggressive and corrosive cleaning agents.
- Allow the machine to dry after being cleaned, e.g. over the weekend.
- Only start the machine up when all the safety equipment has been installed and brought to its protecting position.

## 1.5 Particular risks

### Electronics

- In the case of defects in the electrical installation, switch the machine off immediately and clear the fault.
- Work on the electrical equipment may only be carried out by electricians who have received the necessary training
- The machine's electrical equipment must be inspected/checked at regular intervals. Defects, such as loose connections and cable damage, must be rectified immediately.

### Batteries

- It is possible that sparking will occur when connecting the batteries.
- Batteries may only be handled and changed by properly skilled maintenance personnel.
- The machine has been set up for operation using maintenance-free batteries. If other battery types are used, the machine must be set up for use with them by an authorized Tornado service center.
- Never lay any metallic objects or tools on batteries - risk of short circuit!

## 1.6 Environmental protection

- A certain factual expertise is required in order to use substances which could represent a risk to health and the environment.
- Observe the applicable laws and local regulations when disposing of waste.
- Used batteries with the recycling symbol contain reusable commodities. In accordance with symbol with the crossed out bin, these batteries must not be disposed of in domestic waste.

## 1.7 Labels on the machine

The following safety and warning labels are attached to the machine where easily legible. Missing or illegible labels must be replaced immediately.

*Company logo*



*Maximum permissible gradient*



*Filter shaker*



*Rating plate*

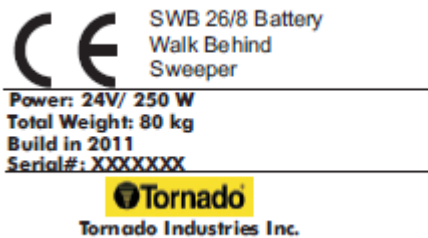

*Wear compensator for side brush*



*Read and observe the operating manual*



*Wear compensator for rotary brush*



## 2 Starting Up

### 2.1 Unpacking and assembling

Open the box, two people are required to remove the machine from the protective wrap and place it on the floor.

1. To fix the side brush (Fig 1/1) align the drive pins on the side brush drive plate and secure with the wing bolt and washer supplied.
2. Loosen the two knurled screws (Fig. 1/2) holding the handle a few revolutions until the handle can be raised and positioned. Set the handle to a height comfortable for the user and then tighten the knurled screws.
3. Remove the locking bolt (Fig 1/3) holding the hood and pivot the hood open.
4. Fix the disassembled cable lug (Fig. 2) to the corresponding battery contact. It is possible that sparking will occur when connecting the batteries!
5. Close the hood and lock in place with the bolt.
6. The unit is now ready to operate.

Fig 2

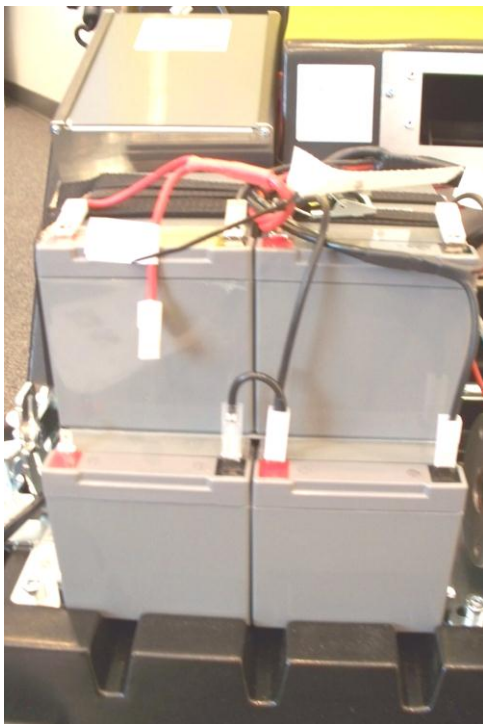

Fig 1



Fig 1/2

Fig 1/1

Fig 1/3

## 2.2 Instruction

Instructions to operators are required before putting the machine into service.

Only technicians from your local, authorized Tornado dealer are allowed to provide initial instruction on how to use the machine.

## 2.3 Initial battery charge



Before starting the machine up for the first time, the batteries to be used must be fully charged, properly, by

implementing the initial battery charge routine.

## 2.4 Prior to starting up

Carry out the following checks before starting the machine:

1. Check the charge status of the batteries.

2. Check the levels of wear on the rotary brush and side brush.

3. Check the fill level of the debris container.

## 2.5 Operation

Please read the Safety Information in Chapter 1. Before switching the machine on, ensure that the drive bar (Fig. 3/3) on the handle has not been actuated.

1. Switch the machine on using the (Fig. 3/1) button: rotary brush drive, dust vacuum and side brush drive are ready to operate.
2. Lower the side brush to its working position using the lever (Fig. 3/4). When working without the side brush: do not lower the side brush and press the button (Fig. 3/2) for the side brush once. The green control lamp goes out.
3. Actuate the drive bar (Fig. 3/3) on the handle: the machine starts to work.



Start work immediately after actuating the drive bar, otherwise imprints could be produced on the floor. Release the drive bar when driving over thresholds.

Fig.3

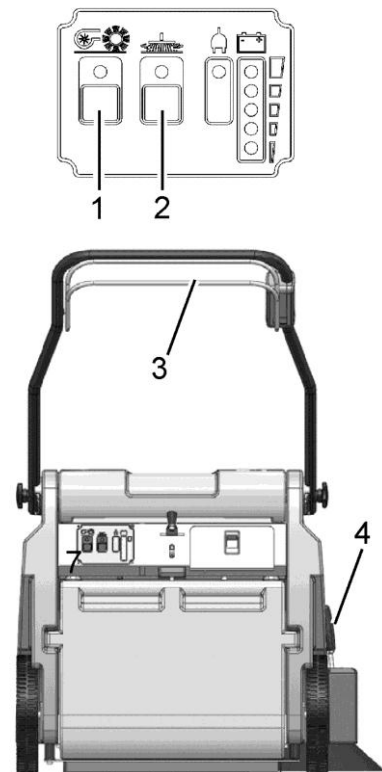

## 2.6 Stopping the machine

When the drive bar is released, the rotary brush drive, dust vacuum and side brush drive switch off automatically.

## 2.7 After completing work

1. Drive to an appropriate maintenance area.
2. Stop the machine. Raise the side brush to its idle position and switch the machine off.
3. Actuate the filter shaker.
4. Empty the debris container.
5. Check the brush space for accumulations of dirt.
6. Check the charge status of the batteries.



It is not permitted to clean the machine with a pressure washer or steam blaster.

## 3 Operation

### 3.1 Method of operation

The Tornado SWB 26/8 is a machine designed to sweep and clean waste from hard floors and carpets. The side brush (Fig. 4/1) sweeps the dirt from corners to a position in front of the rotary brush (Fig. 4/2). The rotary brush sweeps the larger particle dirt overhead into the debris container (Fig. 4/3). The finer dust picked up is drawn up by the suction turbine, fed into the filter system (Fig. 4/4) and filtered out.

Only dust-free air is fed back into the ambient air. The machine is equipped with maintenance-free batteries (Fig. 4/5), a specially adapted, fully automatic battery charger (Fig. 4/6) and a total discharge signal transducer to protect it against total discharge.

Fig. 4

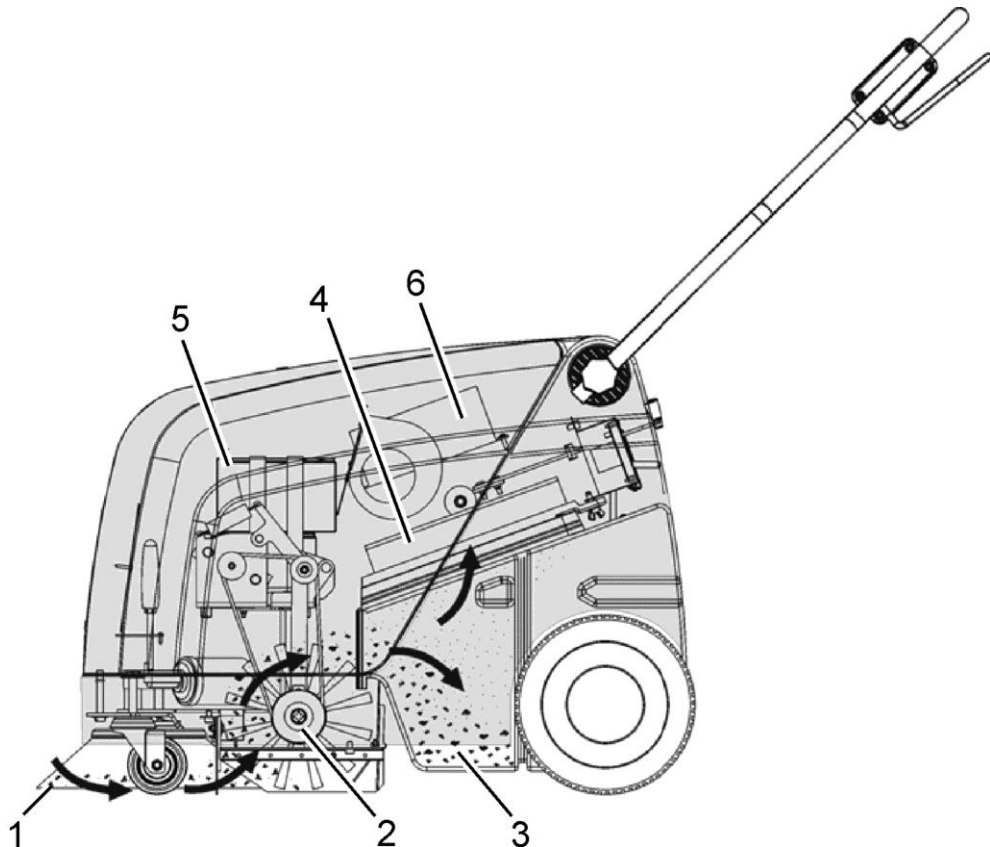

## 3.2 Operating and indicator elements

### 3.2.1 Operating panel

1. Control lamp for rotary brush drive, side brush drive and suction turbine
2. ON/OFF button for rotary brush drive, side brush drive and suction turbine
3. Control lamp for side brush drive
4. ON/OFF button for side brush drive
5. Control lamp for battery charger operation
6. Charge control indicator
7. Drive bar

Fig. 5

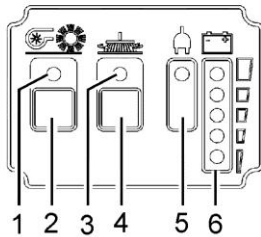

#### ON/OFF button for rotary brush, side brush and suction turbine (Fig. 5/1)

The button activates the rotary brush drive, side brush drive and suction turbine so they are ready to operate.

The side brush drive can be switched off separately. The suction turbine cannot be switched off separately which prevents the dust vacuum being activated by accident.



To prevent unauthorized use of the machine, switch the machine off using the button (Fig. 5/1).

#### Control lamp for rotary brush drive, side brush drive and suction turbine (Fig. 5/2)

The green control lamp indicates that the rotary brush drive and suction turbine are ready to operate. If the rotary brush or suction turbine is overloaded, a safety shutdown is triggered and the control lamp flashes.

#### ON/OFF button for side brush drive (Fig. 5/3)

The button can be used to switch off the side brush drive independently of the rotary brush drive and to activate it for use again.

Fig. 5/7

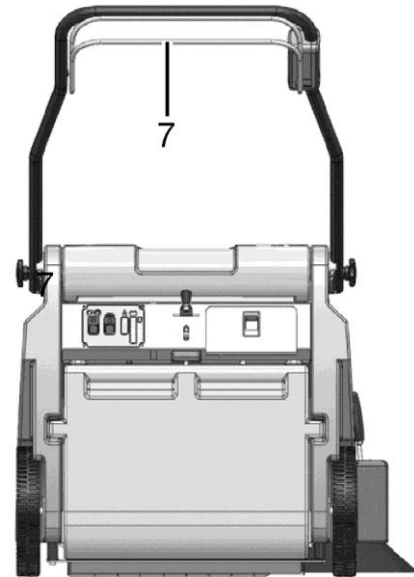

#### Control lamp for side brush drive (Fig. 5/4)

The green control lamp indicates that the side brush drive is ready to operate. If the side brush is overloaded, a safety shutdown is triggered and the control lamp flashes.

#### Control lamp for battery charger operation (Fig. 5/5)

This control lamp indicates that the batteries are being charged

#### Charge control indicator (Fig. 5/6)

During the charging process, the machine's electronics system controls the machine is not switched on inadvertently and indicates the charge status. The battery charge status is indicated by 4 green and 1 red LED.

The battery voltage is depicted in 5 levels:

- > 25.1 V = all green LEDs on
- > 24.5 V = bottom 3 green LEDs on
- > 23.9 V = bottom 2 green LEDs on
- > 22.7 V = bottom green LED on
- < 22.7 V = red battery LED flashes

#### Drive bar (Fig. 5/7)

The drive bar switches all the drives which are ready to operate on or off.

The drive bar serves to prevent damage.

If the drive bar is released during operation, all the drives are switched off.

### 3.2.2 Operating elements on the machine

- 1 Knurled screw for the handle
- 2 Shaking device lever
- 3 Debris container lock
- 4 Side brush lever
- 5 Charger cable flap

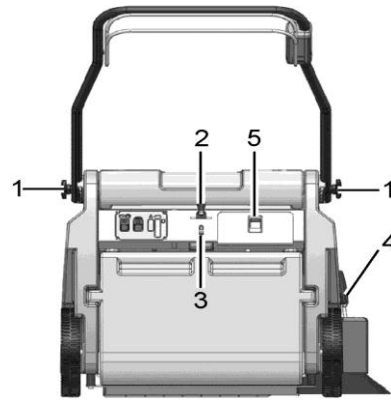

Fig. 6

#### Knurled screws for handle (Fig. 6/1)

The two knurled screws enable the handle to be adjusted to a comfortable height for the user.

#### Shaking device lever (Fig. 6/2)

In order to clean the filter in the dust vacuum, switch the shaking device lever several times quickly to the left and right.

#### Debris container locks (Fig. 6/3)

Pull the lock lever up in order to remove the debris container.

#### Side brush lever (Fig. 6/4)

Use the lever to lower or raise the side brush.

#### Charger cable flap (Fig. 6/5)

The battery charger cable is located behind the flap to the right beside the operating panel. Pull the lock downwards to open the flap.

## Technical Data

Machine length	cm/in	80/32
Machine height (handle folded)	cm/in	60/24
Machine width	cm/in	70/28
Working width	cm/in	66/26
Rotary brush width	cm/in	40/16
Rotary brush diameter	cm/in	19/7
Area Coverage, theoretical	m <sup>2</sup> /sqft/h	2400/26000
Debris Container Volume	Liter/Gal	40/9
Filter Surface	m <sup>2</sup> /sqft	1.1/12
Nominal Voltage	V	24
Power Consumption, rotary brush drive	W/A	210/8.75
Power Consumption, side brush drive	W/A	48/2
Power Consumption, suction turbine	W/A	60/2.5
Weight without batteries	kg/lbs.	42/93
Weight with batteries	kg/lbs	56/124
<b>Noise emission value</b>		
The sound pressure level (LpA) (at the ear of the operator) measured according to DIN IEC 60335-2-72 under normal working conditions:	dB (A)	70
Measurement inaccuracy (KpA):	dB (A)	2

## 5 Maintenance and Service

### General information

It is essential to pay attention to the information in Chapter "Safety Information" before completing any service or maintenance work! By adhering to the maintenance work recommended by us, you can be sure that the machine is always ready to be put into operation. Maintenance and repair work necessary on a daily and weekly basis can be carried out by an operator trained to complete the work, all other Tornado system maintenance may only be

completed by personnel who are correspondingly qualified and trained.

Please contact your nearest Tornado service center or Tornado authorized dealer.

Failure to observe this annuls any rights to claims under the terms of guarantee in respect of resulting damage or consequential damage.

Always specify the serial number in the case of inquiries and spare parts orders, refer to section 1.7 - Rating plate.

### 5.1 Maintenance Plan

#### System maintenance, customer

The following maintenance work must be completed by the customer at the intervals stipulated.

Activity	Interval	
	Daily	Weekly
Check the battery charge; recharge if necessary	o	
Empty the debris container	o	
Clean the brush space	o	
Check the filter in the dust vacuum; clean, if necessary	o	
Check the rotary brush and side brush; clean, if necessary	o	
Check the sweeping pattern; readjust, if necessary		o
Check the sealing strips on the rotary brush for signs of wear; clean, if necessary		o
Check the gasket on the debris container		o
Check the function of the suction turbine		o
Check the debris container lock		o
Test drive and function test		o

## 5.2 Battery system

1. Battery indicator for charger
2. Charge control indicator
3. Charger
4. Flap for charger mains power cable
5. Connection cable
6. Lashing straps
7. Batteries
8. Hood
9. Connection plan



Batteries may only be handled and changed by properly skilled maintenance personnel. The charge control indicator (Fig. 7/2) indicates the charge status of the batteries during operation. When the batteries are discharged, the red LED flashes. The machine functions are restricted. Charge the batteries immediately!

Fig. 7

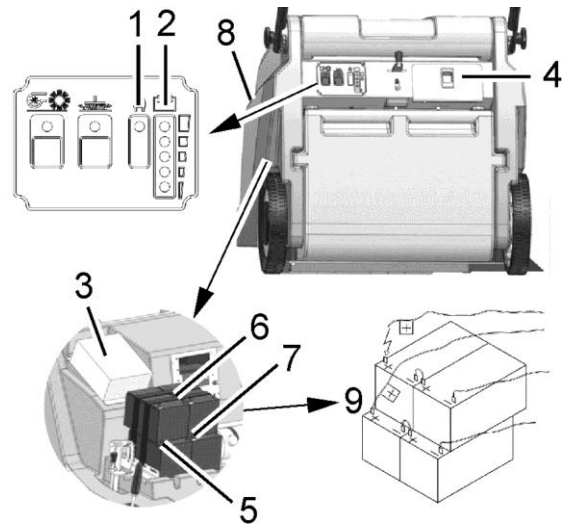

### 5.2.1 Charging batteries

The charge control indicator (Fig. 7/2) indicates the charge status of the batteries during operation. The batteries must be charged immediately the red LED lights up. The batteries (Fig. 7/7) are charged using the integrated battery charger (Fig. 7/3). The charger is connected by means of the power cable (Fig. 7/4).

While the battery is being charged, the battery indicator on the charger (Fig. 7/1) lights up.



Before starting the machine up for the first time, the batteries to be used must be fully charged, properly, by implementing the initial battery charge routine. Tornado assumes no liability for damage to the battery caused by a fault when the battery is charged for the first time.

### 5.2.2 Total discharge signal transducer (TSG)

The machine is equipped with a total discharge signal transducer to protect the batteries against total discharge.

The total discharge signal transducer is integrated in the electronics.

### 5.2.3 Servicing the driving batteries

Never leave discharged batteries lying around; recharge them immediately!

### 5.2.4 Removing the batteries

1. Park the machine on a level area of floor.
2. Switch off the machine.
3. Loosen the locking bolt holding the hood (refer to Figure 1/3) and pivot the hood open.
4. Slacken the lashing straps (Fig. 7/6).
5. Disconnect the connection cable (Fig. 7/5) from the batteries and remove the batteries.

### 5.2.5 Inserting the batteries



Only the special batteries approved by Tornado may be installed at the prescribed position.

1. Install the two lower batteries in the battery holder in accordance with Figure 7.
2. Lay the rubber mat on the batteries.
3. Place the other two batteries on the rubber mat.
4. Tighten the lashing straps (Fig. 7/6).

### 5.2.6 Disposing of batteries

Used batteries with the recycling symbol contain reusable commodities. In accordance with symbol with the crossed out bin, these batteries must not be disposed of in domestic waste.

### 5.3 Side brushes

1. Side brushes
2. Wing bolt
3. Carrier
4. Hood
5. Adjusting bolt
6. Counternut
7. Locking bolt

#### 5.3.1 Changing the side brush

Check the side brush (Fig. 8/1) weekly and change in the case of wear.

1. Switch the machine off and lay it on its side.
2. Remove the wing bolt (Fig. 8/2) with the washer from underneath the side brush (Fig. 8/1).
3. Pull the side brush off.
4. To fix the side brush align the drive pins on the side brush drive plate and secure with the wing bolt and washer supplied.

#### 5.3.2 Setting the sweeping pattern

In the case of brush wear and after changing the side brush (Fig. 8/1), readjust the sweeping pattern.

1. Switch the machine off; unscrew the locking bolt (Fig. 8/7) and open the hood (Fig. 8/4).
2. Loosen the counternut (Fig. 8/6) and adjust the sweeping pattern by turning the adjusting bolt (Fig. 8/5) clockwise and counter clockwise so that it touches the floor.
3. Tighten the counternut again and close the hood.
4. Switch the machine on and allow the side brush to run while standing still for a short time.
5. Switch the machine off, raise the front a little and pull it back.

5. Connect the battery poles to the connection cables in accordance with the connection plan (Fig. 7/9).

It is possible that sparking will occur when connecting the batteries! Check a firm fit!

6. Close the hood (Fig. 7/8) and lock in place with the locking bolt on the frame.

Fig 8

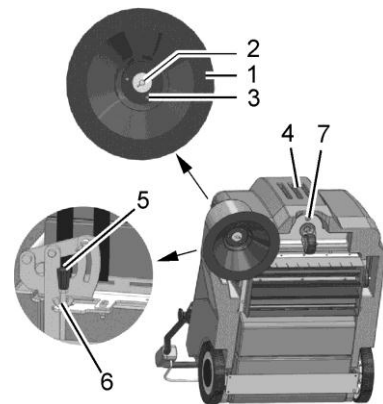

6. Check the sweeping pattern, comparing it with a clock viewed driving forward. When set correctly, the sweeping pattern must make an impression on the floor between approx. 10:00 and 4:00 o' clock.

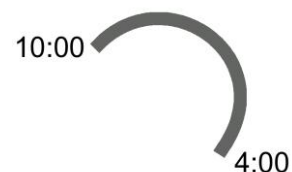

7. Repeat the process, if necessary, until the sweeping pattern is set correctly.

- Close the hood (Fig. 8/4) and screw the locking bolt (Fig. 8/7) back in.

#### 5.4 Rotary brush

- Rotary brush
- Fillister head self-tapping screws
- Rotary brush segment
- Sealing strips
- Sweeping pattern adjusting lever
- Timing belt
- Hood
- Locking bolt

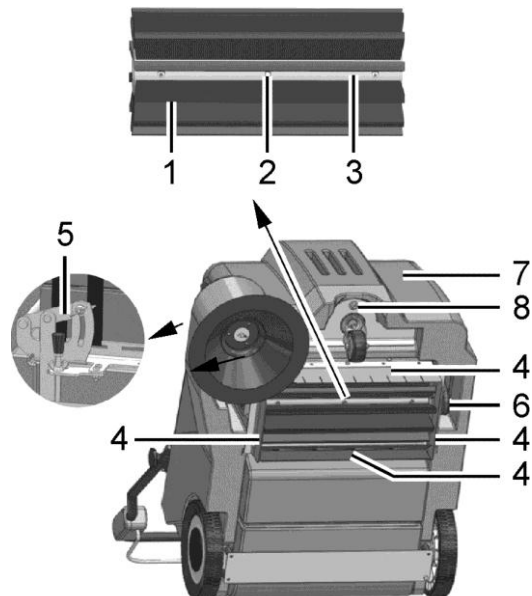

Fig 9

##### 5.4.1 Cleaning the brush space

The brush space with rotary brush (Fig. 9/1) and gaskets (Fig. 9/4) must be checked daily for signs of dirt and cleaned, if necessary.

##### 5.4.2 Changing the rotary brush

The rotary brush (Fig. 9/1) must be checked weekly and changed in the case of wear.

- Switch the machine off and lay it on its side.
- Loosen the six fillister head screws (Fig. 9/2) in the rotary brush and remove the two roller segments.

- Install the two new roller segments and fix in place with the fillister head screws.
- After changing the rotary brush, readjust the sweeping pattern as necessary.

##### 5.4.3 Setting the sweeping pattern

In the case of brush wear, and after changing the rotary brush (Fig. 9/1), readjust the sweeping pattern.

- Switch the machine off, unscrew the locking bolt (Fig. 9/8) and open the hood (Fig. 9/7).
- Loosen the wing nut on the adjusting lever (Fig. 9/5) and adjust the sweeping pattern using the adjusting lever by pivoting it up and down until it touches the floor.
- Tighten the wing nut again and close the hood.

- Switch the machine on and allow the rotary brush to run while standing still for a short time.
- Switch the machine off, raise the front a little and pull it back.
- When adjusted correctly, there must be an approx. 50 mm wide sweeping pattern on the floor which has parallel sides.
- Repeat the process, if necessary, until the sweeping pattern is set correctly.
- Close the hood (Fig. 9/7) and screw the locking bolt (Fig. 9/8) back in

##### 5.4.4 Changing the sealing strips

The four sealing strips (Fig. 9/4) must be checked weekly and changed in the case of wear.

- Switch the machine off and lay it on its side.
- Remove all four sealing strips (Fig. 9/2) with holders.

- Loosen the screws in the holders and remove the damaged sealing strips.
- Fix the new sealing strips on the holders and reinstall them.
- Adjust the sealing strips so that they touch the floor lightly.

### 5.4.5 Changing the timing belt

The timing belt (Fig. 9/6) must be checked every 500 operating hours and changed in the event of wear.

1. Switch the machine off, unscrew the locking bolt (Fig. 9/8) and open the hood (Fig. 9/7).
2. Slacken the timing belt (Fig. 9/6) using

the tension pulley and remove the belt.

3. Slacken the tension pulley and install the new timing belt. The timing belt is automatically tensioned by means of a tension spring.

4. Close the hood (Fig. 9/7) and screw the locking bolts (Fig. 9/8) back in.

### 5.5 Debris container

- 1 Debris container
- 2 Locking mechanism
- 3 Seal
- 4 Handle

#### 5.5.1 Emptying the debris container

Check the fill level of the debris container (Fig. 10/1) at regular intervals (max. load capacity 25 kg) and empty as necessary.

1. Switch the machine off and pull the locking mechanism (Fig. 10/2) on the debris container (Fig. 10/1) upwards.

Fig. 10

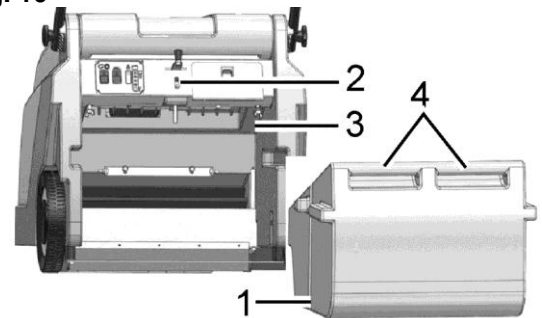

2. Pull the debris container to the rear out of the machine using the handle (Fig. 10/4) and dispose of the waste according to the applicable environmental laws.
3. Reinstall the debris container and press it against the locking mechanism until it audibly latches into place.

#### 5.5.2 Changing the seal

Check the seal (Fig. 10/3) weekly for signs of wear and change it as necessary.

1. Switch off the machine and pull the locking mechanism (Fig. 10/2) on the debris container (Fig. 10/1) upwards.
2. Pull the debris container (Fig. 10/3) to the rear and out of the machine using the handle (Fig. 10/4).

3. Pull the seal for the debris container from the filter support frame. Install a new seal.
4. Reinstall the debris container and press it against the locking mechanism until it audibly latches into place

### 5.6 Dust vacuum

- 1 Filter
- 2 Sealing strip
- 3 Filter support frame
- 4 Shaking device
- 5 Wing bolts
- 6 Holders

Fig. 11

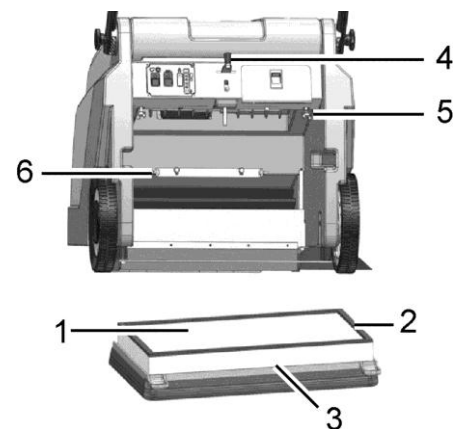

### 5.6.1 Cleaning the filter

Clean the filter (Fig. 11/1) in the dust vacuum as necessary using the shaking device (Fig. 11/4). In the case of extreme accumulation of dirt, clean the filter as follows:

1. Switch the machine off and remove the debris container.
2. Loosen the wing bolts (Fig. 11/5). Pivot the filter support frame (Fig. 11/ 3) down and remove it.
3. Remove the filter from the filter support frame.

### 5.6.2 Changing the filter

Check the filter (Fig. 11/1) every 250 operating hours for signs of wear and change it as necessary.

1. Switch the machine off and remove the debris container.
2. Unscrew the wing bolts (Fig. 11/5). Pivot the filter support frame (Fig. 11/3) down and remove it.

### 5.6.3 Install the Lint filter

If the machine is mainly used on carpet, you have to install the lint filter (7).

1. Switch the machine off and remove the debris container.
2. Unscrew the wing bolts (Fig.11/5). Pivot the filter support frame (3) down and remove it.
3. Mount the lint filter (7) between filter and the filter support frame
4. Hook the filter support frame in the holder (Fig.11/6), if necessary, and fix in place with the wing bolts.

### Noise emission value

The sound pressure level (LpA) (at the ear of the operator) measured according to DIN IEC 60335-2-72 under normal working conditions: 70 dB (A)  
Measurement inaccuracy (KpA): 2 dB (A)

Tornado Industries declares that the products

### **Tornado SWB 26/8**

to which this declaration relates, conform to the relevant provisions of the safety and health requirements stipulated in EC Directive 2006/42/EC and is in accordance with 2004/108/EC.

Beat the filter clean or use a vacuum cleaner. Be careful not to damage the filter ribs!

4. Insert the correct side of filter in the filter support frame. The sealing strip (Fig. 11/2) must point towards the suction turbine!
5. Hook the filter support frame in the holder (Fig. 11/6) and fix in place with the wing bolts.
6. Reinstall the debris container

3. Remove the filter from the filter support frame.
4. Insert the correct side of the new filter in the filter support frame. The sealing strip (Fig. 11/2) must point towards the suction turbine!
5. Hook the filter support frame in the holder (Fig. 11/6), if necessary, and fix in place with the wing bolts.
6. Reinstall the debris container

5. Reinstall the debris container.

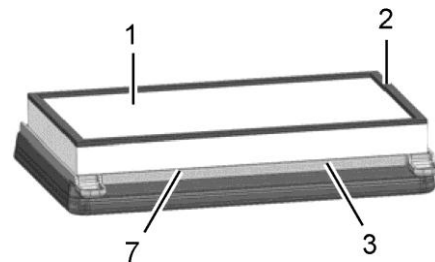

### EC Declaration of Conformity (corresponds to EC Directive 2006/42/EC)

Reference was made to the following standards and/or norms and/or technical specifications to ensure proper implementation of the safety and health requirements in the EC Directive:

**EN 60335-2-72**  
**EN 55012**  
**EN 61000-6-2**