

F32-HD Industrial Floor Scrubber

OWNERS MANUAL

IMPORTANT: READ OWNERS MANUAL CAREFULLY
Please fill out & return your warranty card !

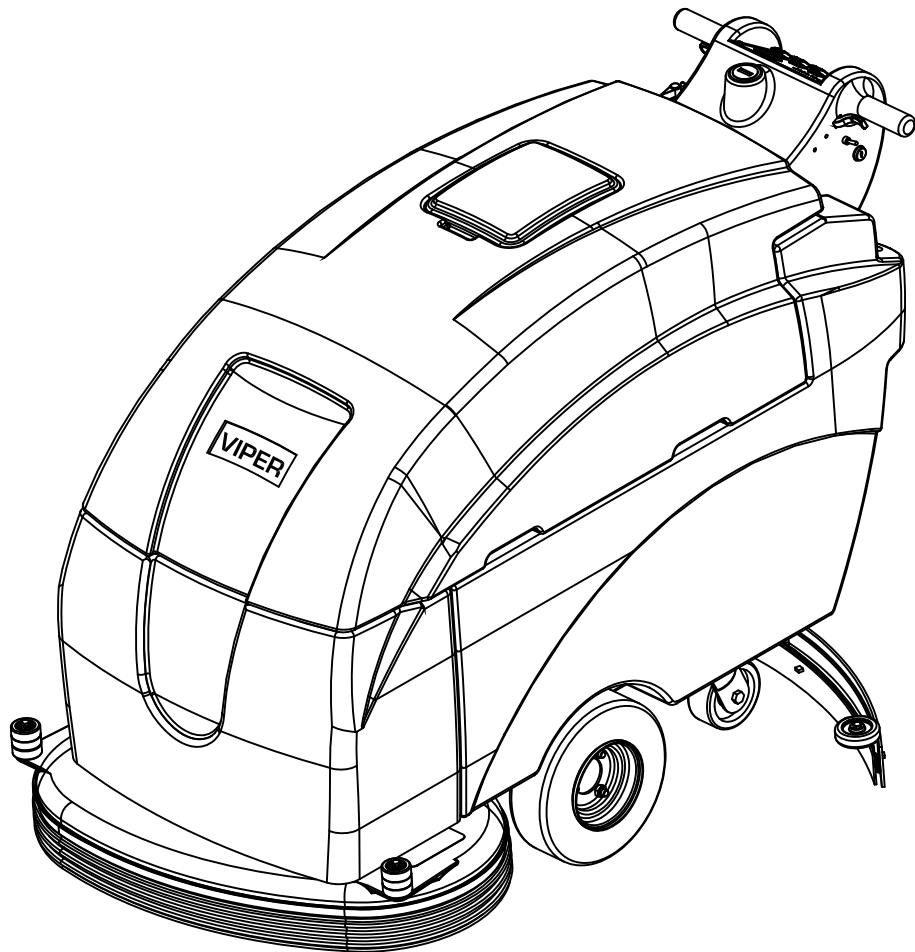

MODEL # _____ FANG 32T
SERIAL # _____





CONGRATULATIONS on your purchase of a Viper product, and welcome to the V.I.P. family. We appreciate your business and will do everything in our power to keep you happy with your purchase for many years to come.

As part of the V.I.P. family, you are entitled to the best protection by one of the most comprehensive warranties in the industry.

Thank-you for purchasing Viper products!

Tom VanderBie, CEO

TABLE OF CONTENTS

SAFETY PRECAUTIONS	3
MACHINE COMPONENTS	4
MACHINE SET UP	5
MACHINE INSTALLATION	5-6
MACHINE OPERATION	6
TANK DRAINING	7
BATTERY CHARGING	7-8
PREVENTATIVE MAINTENANCE	8-9
MACHINE STORAGE	10
BASIC TROUBLESHOOTING	11
PARTS BREAKDOWNS AND LISTS	12-28
WIRING DIAGRAM	29



SAFETY PRECAUTIONS

This machine is intended for commercial use. It is constructed for use in an indoor environment and is not intended for any other use. Use only with recommended accessories.

All operators shall read, understand and exercise the following safety precautions:

1) DO NOT OPERATE MACHINE:

- Unless trained and authorized.
- Unless you have read and understand the operators manual.
- In flammable or explosive areas.
- If not in proper operating condition.
- In outdoor areas.

2) BEFORE OPERATING MACHINE:

- Make sure all safety devices are in place and operate properly.

3) WHEN USING MACHINE:

- Go slow on inclines and slippery surfaces.
- Follow all safety guidelines.
- Be very careful when using the machine in reverse.
- Report and fix any damage to machine prior to operating it.

4) BEFORE LEAVING OR SERVICING MACHINE:

- Stop machine on level ground.
- Turn machine off.

5) WHEN SERVICING MACHINE:

- Read operators manual thoroughly prior to operating or servicing this machine.

- Use manufacturer supplied or approved replacement parts.
- Secure machine with wheel blocks prior to jacking the machine up.
- Use approved jack or hoist to safely elevate the machine.
- Disconnect batteries prior to working on machine.
- Wear gloves when handling batteries or battery cables.
- Avoid any contact with battery acid.
- Avoid moving parts. Do not wear loose fitting clothing while servicing machine.

WARNING

: Batteries emit hydrogen gas. Explosion or fire can result from hydrogen gas. Keep sparks and open flames away! Keep battery compartment open when charging.

WARNING

: Flammable materials can cause an explosion or fire. Do not use flammable materials in tanks.

WARNING

: Flammable materials or reactive metals can cause explosion or fire. Do not pick up.

MACHINE COMPONENTS

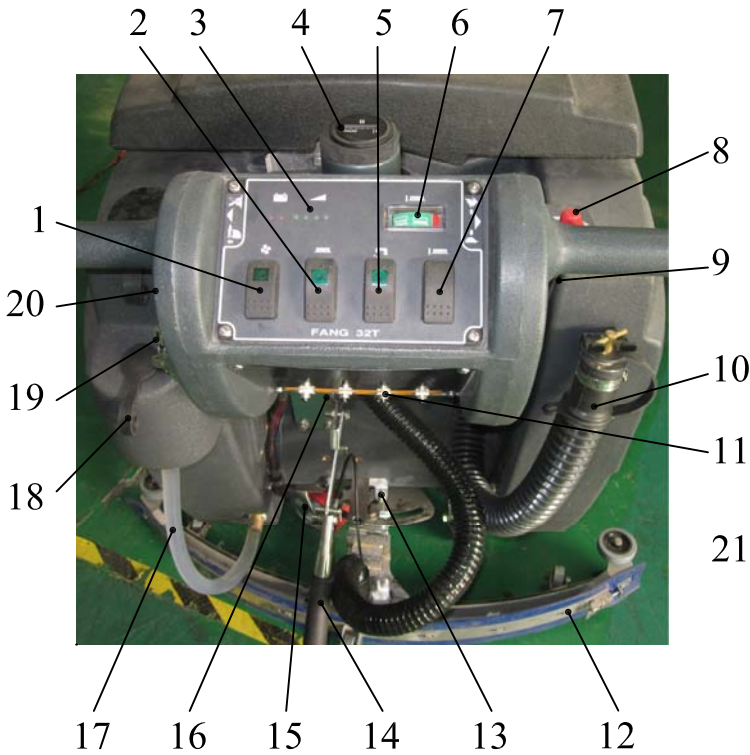

- 1. Vacuum ON/OFF switch
- 2. Brush ON/OFF switch
- 3. Battery level meter
- 4. Hour meter
- 5. Solution ON/OFF switch
- 6. Brush pressure meter
- 7. Brush pressure UP/DOWN switch
- 8. Solution control knob
- 9. Speed control knob
- 10. Recovery tank drain hose
- 11. Circuit breakers
- 12. Squeegee assembly
- 13. Squeegee adjustment nut & shaft
- 14. Squeegee lift lever
- 15. Rear casters
- 16. Console adjustment levers

- 17. Solution tank level sight tube
- 18. Rear solution fill
- 19. Key switch
- 20. Reverse switch
- 21. Front cover
- 22. Scrub head
- 23. Protective rollers
- 24. Scrub head door
- 25. Transport wheels
- 26. Solution tank
- 27. Operating triggers
- 28. Control housing
- 29. Recovery tank lid
- 31. Solution filter assembly
- 32. Recovery tank

MACHINE SET UP & INSTALLATION

UNCRATING MACHINE

Be sure and check packing carton for any damage. Immediately report any damage to carrier. Check contents of package to ensure that the following items are included: Machine, batteries (x6), squeegee assembly, battery charger and pad drivers. (batteries and charger may be on separate skid)

BATTERY CONNECTIONS

The batteries and charger are shipped separately and will need to be installed and connected as shown in the diagram below.

WARNING

Batteries emit hydrogen gas.

Explosion or fire can result from hydrogen gas. Keep sparks and open flames away! Keep battery compartment open while charging.

1. Be sure the power switch is in the "off" position.
2. Open recovery tank to gain access to battery compartment.
3. Carefully place the six batteries into the compartment as shown in figure below. Place the battery brace at the rear of the batteries.
4. Connect battery cables to posts in order as shown in diagram below. (RED to POSITIVE and BLACK to NEGATIVE)

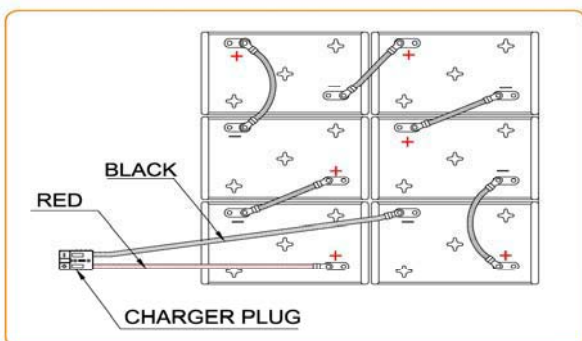

5. Apply a coating or protective spray on the cable connections to prevent battery corrosion.

DO NOT DROP THE BATTERIES INTO COMPARTMENT!

MACHINE SET UP

PRE-OPERATION CHECKS

1. Sweep or dust mop the surface to be cleaned.
2. Check battery meter to make sure batteries are fully charged. (SEE BATTERY CHARGING)
3. Ensure squeegee is properly installed.
4. Ensure that brush/pad is properly installed.

INSTALLING PAD DRIVERS OR BRUSHES

1. Ensure the machine is turned off.
2. Raise the brush head assembly off the floor by pushing on the brush lift button on the control console.
3. Slide back the viewing window panel on the aluminum deck housing.
4. If using a pad driver, first attach the appropriate pad to the bottom of the driver.
5. Slide the pad driver under the deck and look through the viewing panel and line the three lugs with the three holes in the drive motor hub. Once in the holes, rotate the driver toward the spring clip to lock the driver in place

MOUNTING THE SQUEEGEE

1. Pull the squeegee lift lever to raise the squeegee bracket up.
2. Loosen the two knobs on the squeegee and slide the squeegee into the slots at the rear of the squeegee bracket. (the wheels on the squeegee point to the back)
3. Tighten the knobs securely.
4. Secure the vacuum hose on the pick-up tube of the squeegee.

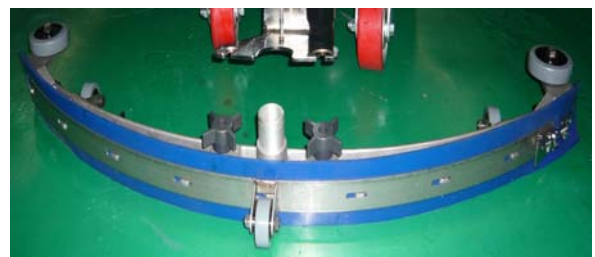

FILLING THE SOLUTION TANK

1. The FANG32T can only be filled in the rear of the machine. There is a fill cap that can be removed so the tank can be filled with a hose.
2. Fill the solution tank with up to 30 gallons of water. (water temperature should not exceed 140 degrees F)
3. The clear tube under the fill port has gallon markers to help determine the water level in the solution tank.

WARNING

:Do not put any flammable materials into solution tank. This can cause an explosion or a fire. Only use recommended cleaning chemicals. Contact your Viper distributor for recommended chemicals.

MACHINE OPERATION

WARNING

:Do not operate machine unless you have read and understand this manual.

1. Before the machine will operate, the key switch must be turned into the "on" position. The key is located on the left side of the control housing. (see machine components, item #19)
2. Set control housing to a comfortable operating height by squeezing together the tow thumb levers directly underneath the housing (see machine components item #16)
3. Lower squeegee assembly to the floor. There is a squeegee lift handle located on the back left of the machine, just under the control housing. (see machine components, item #14) Slightly lift up on the handle and move it to the right, the squeegee is now ready to be lowered to the floor.
4. Lower the brush head to the floor by pushing the brush lower button on the control housing. (see machine components, item #7)
5. Turn vacuum motor switch to "on" position. (see machine components, item #1)
6. Turn the brush motor switch to "on" position. (see machine components, item #2)
 - a. **Brushes will not spin until the operating triggers are pulled.**
7. Turn the solution switch to "on" position. (see machine components, item #3)
 - a. **Solution will not begin to flow until the operating triggers are pulled.**
8. To begin scrubbing, pull on one or both of the red operating triggers. (see machine components, item #27) When the triggers are pulled, the brushes will begin to spin, the solution will begin to flow, and the machine will propel itself.
9. This machine is self-propelled. The speed can be adjusted by a dial located on the right side of the control housing. (see machine components, item #9)
10. This machine has reverse. In order to activate reverse, there is a toggle switch on the left side of the control housing. (see machine components, item #20) The toggle switch must be pulled / pressed to activate reverse motion.

HINT

:Do not keep the machine in the same position with the pad / brush spinning , or you could cause damage to the floor.

11. Adjust the amount of solution flow by turning the solution control knob. Turn the knob to the right for more solution, or turn left for less solution. (see machine components, item #8)
12.  There is a hour meter located on the top of the control housing. (see machine components, item #4) The operator can see the operation time.

WHILE OPERATING MACHINE

1. Occasionally look through the clear recovery tank lid to see if there is any foam build-up. If excessive foam is found, add defoamer to the recovery tank.

WARNING

:Foam must not enter the float shut-off screen, or damage can occur to the vacuum motor. Foam will not activate the machines float shut-off device.

2. Occasionally view the clear tube at the back left of the machine to check the amount of cleaning solution that is left in the machine.
3. Occasionally check the battery level meter. (see machine components, item #3) When the meter is in the red, recharge the batteries.

WARNING

:When battery meter is in the red, do not continue to operate the machine. Battery damage may occur.

4. If the squeegee assembly leaves streaks on the floor, raise the squeegee off the floor and wipe the blades down with a damp cloth.

WARNING

:Do not use your fingers to wipe or remove debris from the blades, as injury may occur.

5. When the solution tank runs empty, turn off the brush switch, solution switch, and raise the brush head. Keep the squeegee down and continue to vacuum until all the dirty water is picked up. (see TANK DRAINING section to learn how to drain recovery and solution tanks)

HINT

:The brush motors are circuit breaker protected to protect them from damage. If a breaker trips, it can't be reset immediately. You must first determine what caused the breaker to trip, and allow the motor to cool down before you can reset the breaker. The

breakers are located on the rear panel of the control housing.

TANK DRAINING

1. Turn the power off on the machine
2. With the squeegee and brush head in their "up" position, transport the machine to an approved area for draining the tank(s).

DRAINING THE RECOVER(DIRTY) TANK

HINT

:Anytime scrubbing is completed, or when refilling the solution tank, the recovery tank should also be drained and cleaned.

WARNING

If the recovery tank is not drained when the solution tank has been refilled, foam or water may enter the float shut-off mechanism and cause damage to the vacuum motor.

1. Remove the drain hose from the holder and place the drain hose over a floor drain. Twist off the drain hose plug to begin the draining process. In order to completely empty the recovery tank, hinge open the recovery tank and let it rest on the support stand.
2. Clean the recovery tank after every use. Use a fresh water hose to rinse out the inside of the tank. Be careful not to spray water into the float shut-off mechanism.

HINT

:If you are storing the machine for any period of time, always leave the clear recovery tank lid off the tank so the tank may dry completely, and smell fresh.

2. Replace the drain hose plug tightly as soon as you are done draining the tank.

DRAINING THE SOLUTION(CLEAN)TANK

HINT

:Anytime scrubbing operation is completed, the solution tank should be drained and cleaned.

1. Pull down on the clear tube (back left of the machine) to remove it from the hose barb. This will allow the solution to flow freely into a bucket or floor drain.
2. Rinse the solution tank with clean water after every use. This will help prevent chemical buildup and clogging of the solution lines.
3. With clean water in the solution tank, turn machine power on, solution switch "on" and pull the operating triggers. This will allow the clean water to flush through and clean the solution plumbing.
4. Once the tank is rinsed, flushed and drained, reconnect the clear tube to the hose barb. Be sure the tube is pushed all the way up on the hose barb

BATTERY CHARGING

WARNING

:Use only approved chargers with the following specifications:

- Automatic shut-off circuit
- Deep cycle charging
- Output current of 20-30 Amps.
- Output voltage of 36 volts.

HINT

:For the best machine performance, keep batteries charged at all times. Do not let them sit in a discharged condition discharged condition.

WARNING

:Batteries are dangerous! Batteries emit hydrogen gas and an explosion or fire can result. Keep sparks and fire away from batteries at all times. When charging the

machine, make sure the battery compartment is left open.

1. Place charger and machine in a well ventilated area.
2. Turn machine off.
3. Open recovery tank up, exposing battery compartment.
4. Check fluid level in each battery cell. Do not charge batteries unless fluid is slightly covering the battery plates. Do not overfill the batteries. Overfilling may cause the batteries to overflow during charging due to expansion. Replace the caps prior to charging.
5. Plug approved charger into grounded wall outlet before plugging the charger into the machine.
6. Plug charger into grey charger receptacle located in the front left of the battery compartment.
7. Flip up the recovery tank "kick stand" and gently lay the recovery tank down until it rests on the stand.
8. The charger will automatically begin to charge the batteries, and it will automatically shut down once the batteries are fully charged.
9. Upon completion of charging, first unplug the charger from the wall outlet and then disconnect the charger from the machine.
10. Check the battery fluid level after charging is completed. If the fluid level is low, add distilled water to bring the fluid level up to the bottom of the sight tubes. Replace the caps and wipe the batteries down with a towel.



PREVENTITIVE MAINTENANCE

WARNING

Before performing any maintenance on the machine, be sure that the power is turned off, or the batteries disconnected.

WARNING

Repairs are to be completed by an authorized Viper service center only. Any repairs completed by unauthorized persons will void the warranty.

DAILY MAINTENANCE

1. Remove pad driver / brush and clean with approved cleaner.
2. Drain recovery and solution tanks completely and rinse out with clean water. Visually check the recovery tank for debris and clean out as necessary.
3. Raise squeegee assembly off the floor and wipe it down with a damp towel. Be sure to store the squeegee in the up position.
4. Remove the float shut-off assembly and rinse it out with clean water.



5. Clean machine with an approved cleaner and a damp towel.
6. Recharge batteries.

WEEKLY MAINTENANCE

1. Check fluid level in batteries.

2. Check batteries for loose or corroded cables.
3. Keep battery tops clean from corrosion.

MONTHLY MAINTENANCE

1. Check machine for leaks and loose fasteners.
2. Lubricate all grease points and pivot points with silicon spray and approved grease.
3. Place machine over a floor drain. Flush solution system by pouring 3 gallons of hot water and approved alkaline detergent into the solution tank and running machine (with solution control on) for 45 seconds. Turn machine off and let it sit over-night. The following day, drain the remaining solution and rinse the solution tank out with clean water.

VACUUM MOTOR MAINTENANCE

1. Contact your local Viper Distributor for any motor maintenance.
2. Vacuum motor should have the brushes checked every 250 hours. Brushes should be replaced when they are worn to a length of 10mm or less.

BATTERY MAINTENANCE

HINT

:For the best machine performance, keep batteries charged at all times. Do not let them sit in a discharged condition.

WARNING

:Batteries are dangerous! Batteries emit hydrogen gas and an explosion or fire can result. Keep sparks and fire away from batteries at all time.

WARNING

:Whenever servicing batteries, be sure to wear protective gloves. Avoid contact with battery acid at all times!

1. Always follow the battery charging directions as outlined in the BATTERY CHARGING section of this manual.

2. Keep battery tops and terminals free from corrosion. A strong solution of baking soda and water is the best way to keep the batteries corrosion free. **DO NOT ALLOW THE BAKING SODA / WATER SOLUTION TO ENTER THE BATTERY CELLS.**
3. Use a wire brush with the baking soda solution to properly clean the battery posts and connections.
4. Check battery connections for wear and loose terminals. Replace if necessary.

MACHINE STORAGE

1. Always store the machine indoors.
2. Always store the machine in a dry area.
3. Always store the machine with pads brushes removed.
4. Always store the machine with the squeegee assembly in up position.
5. If storing in an area which may reach freezing temperatures, be sure to drain all fluids from the machine prior to storage. Any damage caused by freezing temperatures will not be covered by the warranty. Remove VF80111 solution filter cover to drain all fluid form hoses.
6. Drain the recovery tank and remove the clear lid on the top of the recovery tank so that it can "breathe" during storage.
7. Drain the solution tank of all fluid.

BASIC TROUBLESHOOTING

PROBLEM	CAUSE	SOLUTION
No power	Bad batteries	Replace batteries
	Key not in "ON" position	Turn key "ON"
	Main circuit breaker tripped	Contact Viper Distributor
	Batteries need to be charged	Charge batteries (see Battery Charging)
	Loose battery cable	Tighten loose cable(s)
	Batteries not connected properly	Follow battery installation instructions
Brush motor does not run	Bad brush switch	Contact Viper Distributor
	Brush circuit breaker has tripped	Check brush motor for obstructions and reset breaker
	Bad wiring	Contact Viper Distributor
	Bad brush motor	Contact Viper Distributor
	Carbon brushes worn out	Contact Viper Distributor
	Bad solenoid	Contact Viper Distributor
Vacuum motor does not run	Bad vacuum switch	Contact Viper Distributor
	Bad wiring	Contact Viper Distributor
	Bad vacuum motor	Contact Viper Distributor
	Carbon brushes worn out	Contact Viper Distributor
Short run time	Batteries need to be charged	Charge batteries (see Battery Charging)
	Batteries need maintenance	See Battery Maintenance in this manual
	Bad cell in battery(s)	Replace batteries
	Bad charger	Replace charger
Little or no solution flow	Bad solution switch	Contact Viper Distributor
	Clogged solution solenoid	Contact Viper Distributor
	Clogged solution filter	Remove filter and clean
	Solution line obstructed	Remove solution line and clean
	Solution flow adjustment knob in need of adjustment	Increase flow by twisting solution adjustment knob to the right. Decrease flow by twisting solution adjustment knob to the left.
Poor water pick up	Squeegee clogged	Clean debris off squeegee with damp towel
	Squeegee blades worn	Install new squeegee blades
	Squeegee not mounted correctly	Confirm that the squeegee assembly is securely fastened to the machine and not loose fitting.
	Vacuum hoses have a hole or are loose	Check hose connections and make sure they are firm. Replace hose if damaged.
	Vacuum hose may be clogged	Check hose for debris and remove any clog.
	Drain hose stopper is loose	Tighten drain plug.
	Batteries need to be charged	Charge batteries (see Battery Charging)
	Vacuum motor is loose	Tighten vac motor mounting screws. Do not overtighten or damage will occur.
	Recovery tank lid is loose	Confirm the clear recovery tank lid is securely in place.
	Recovery tank inlet hole is clogged	Drain recovery tank and tilt tank on side. Check the inlet hole for debris and remove debris.
	Recovery tank is full	Drain recovery tank.
	Float shut off is clogged	Remove float shut off from inside recovery tank and remove any debris.

FANG 32T - MAIN FRAME AND DRIVE ASSEMBLY

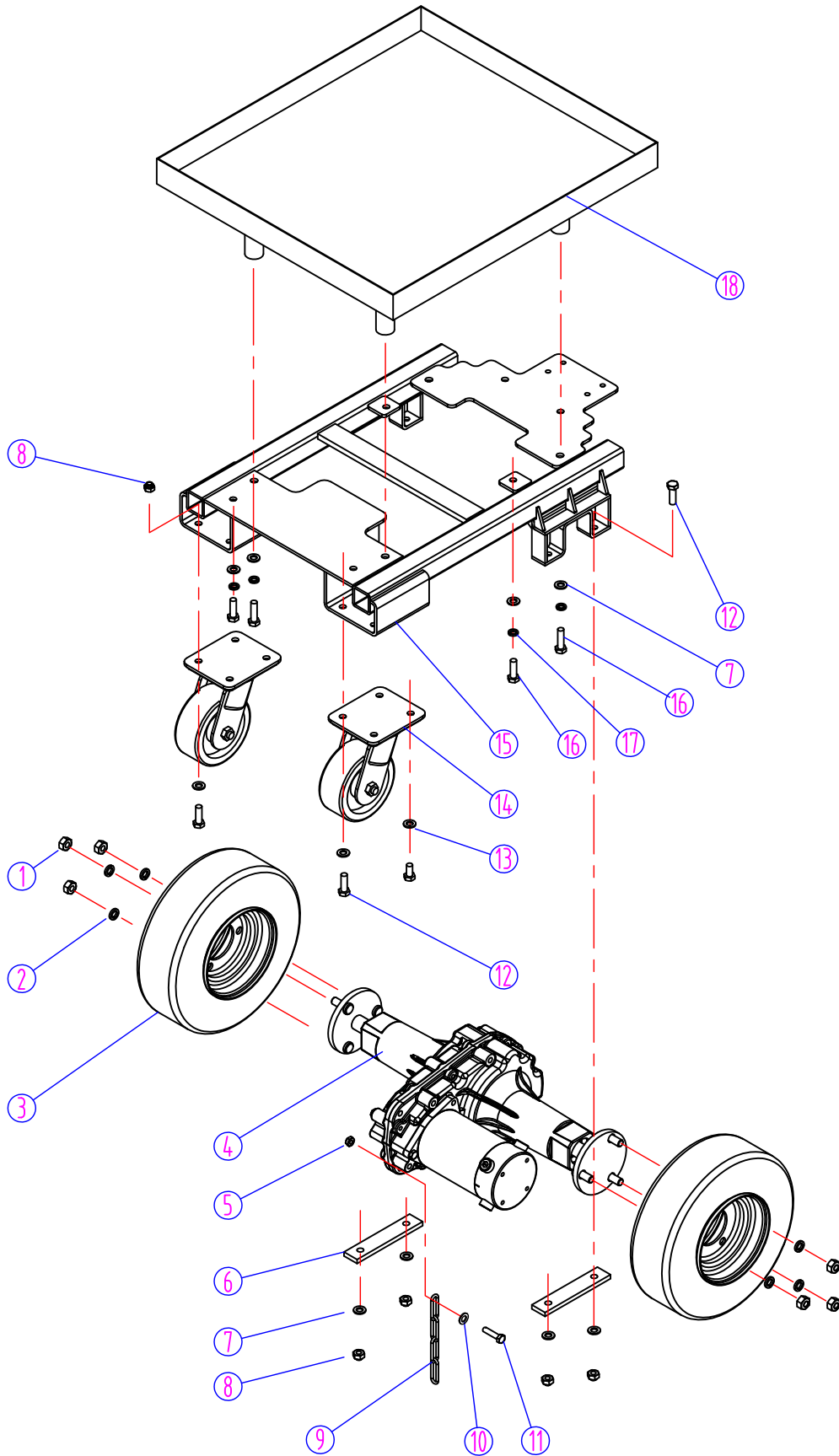

FANG 32T - MAIN FRAME AND DRIVE ASSEMBLY

DIA NO	PART NUMBER	DESCRIPTION	NO REQ'D
1	VF13501A	NUT, M12	6
2	VF13541	WASHER, LOCK, M12	6
3	VF84118	TIRE, FOAM FILLED, BLACK (OPTIONAL)	2
	VF84119	TIRE, BLACK (STANDARD)	2
4	VF84800	TRANSAXLE, 32"	1
	ZD13000	TRANSAXLE MOTOR, 36VDC	1
5	VF13503	NUT, LOCK, M8	1
6	VF84112	PLATE, TRANSAXLE	2
7	VF13517	WASHER, PLAIN, M10 X M26 X 2	14
8	VF13504	NUT, LOCK, M10	12
9	VF84122	CHAIN, STATIC	1
10	VF13535	WASHER, PLAIN, M8 X M20 X 2	1
11	VF14235	SCREW, M8 X 35	1
12	VF14123	SCREW, M10 X 25	12
13	VF13517	WASHER, PLAIN, M10 X M20 X 2.5	8
14	VF84117	CASTER, 5"	2
15	VF84103	FRAME	1
16	VF13634	SCREW, M10 X 30	10
17	VF13518	WASHER, LOCK, M10	10
18	VF84125	BATTERY TRAY	1

FANG 32T - SCRUB HEAD LIFT ASSEMBLY

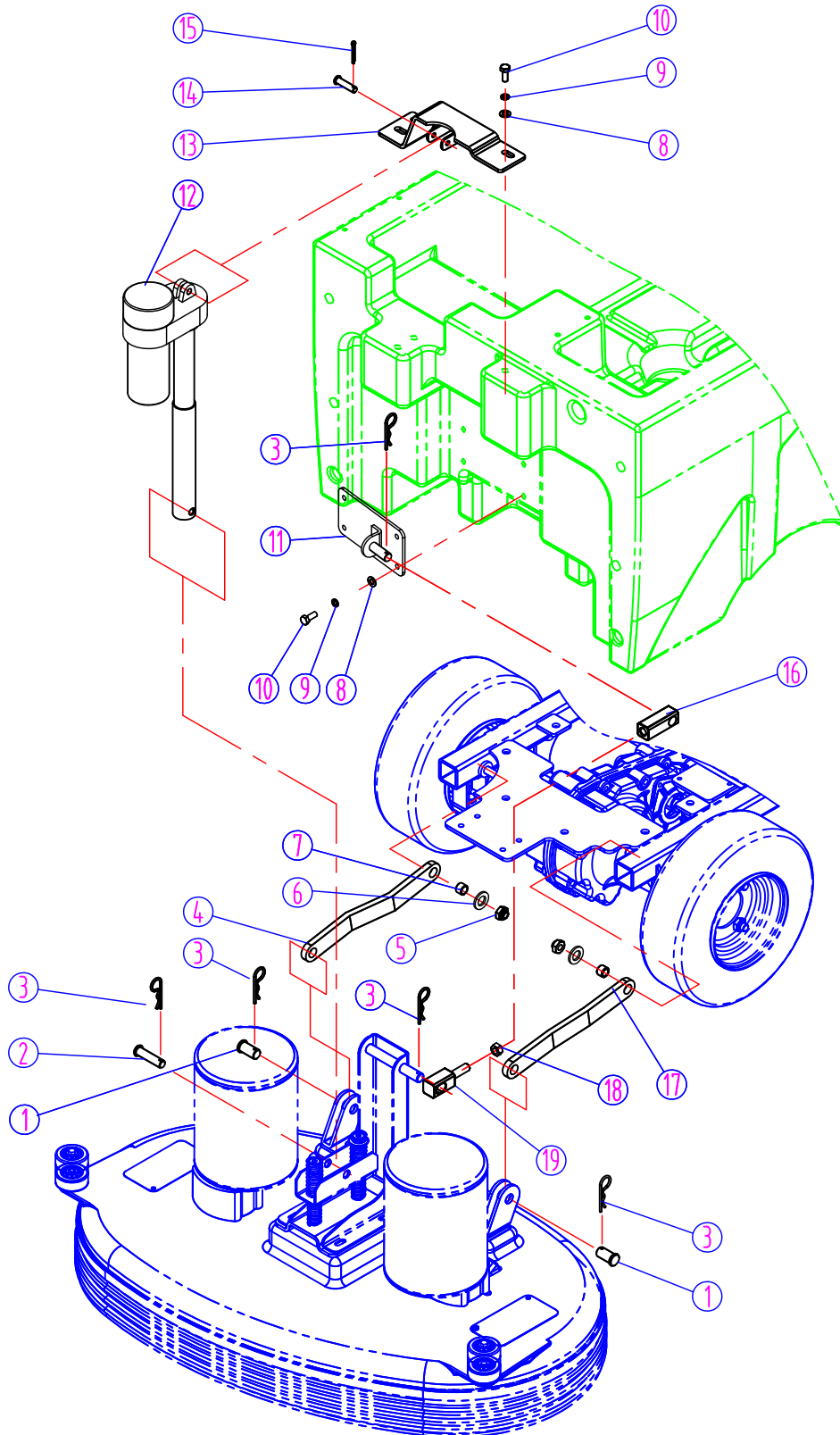

FANG 32T - SCRUB HEAD LIFT ASSEMBLY

DIA NO	PART NUMBER	DESCRIPTION	NO REQ'D
1	VF84316	PIN, M16 X 30	2
2	VF84317	PIN, M13 X 51	1
3	VF84309	PIN, COTTER, M3 X 60.5	5
4	VF84105	ARM, LIFT, LEFT	1
5	VF13501	NUT, LOCK, M12	2
6	VF13538	WASHER, PLAIN, M12 X M22 X 2	2
7	VF84116	BUSHING	2
8	VF13535	WASHER, PLAIN, M8 X M20 X 2	7
9	VF13519	WASHER, LOCK, M8	7
10	VV13604	SCREW, M8 X 20	7
11	VF84336	BRACKET, BRUSH LIFT	1
12	VF84332	ACTUATOR, 36VDC	1
13	VF84310	BRACKET, ACTUATOR	1
14	VF84322	PIN, M9.5 X 37	1
15	VF14084	PIN, COTTER, M3.2 X 24	1
16	VF84337	ADJUST NUT	1
17	VF84121	ARM, LIFT, RIGHT	1
18	VF14057A	NUT, M12	1
19	VF84338	ADJUST SCREW	1

FAN32T - SOLUTION TANK ASSEMBLY

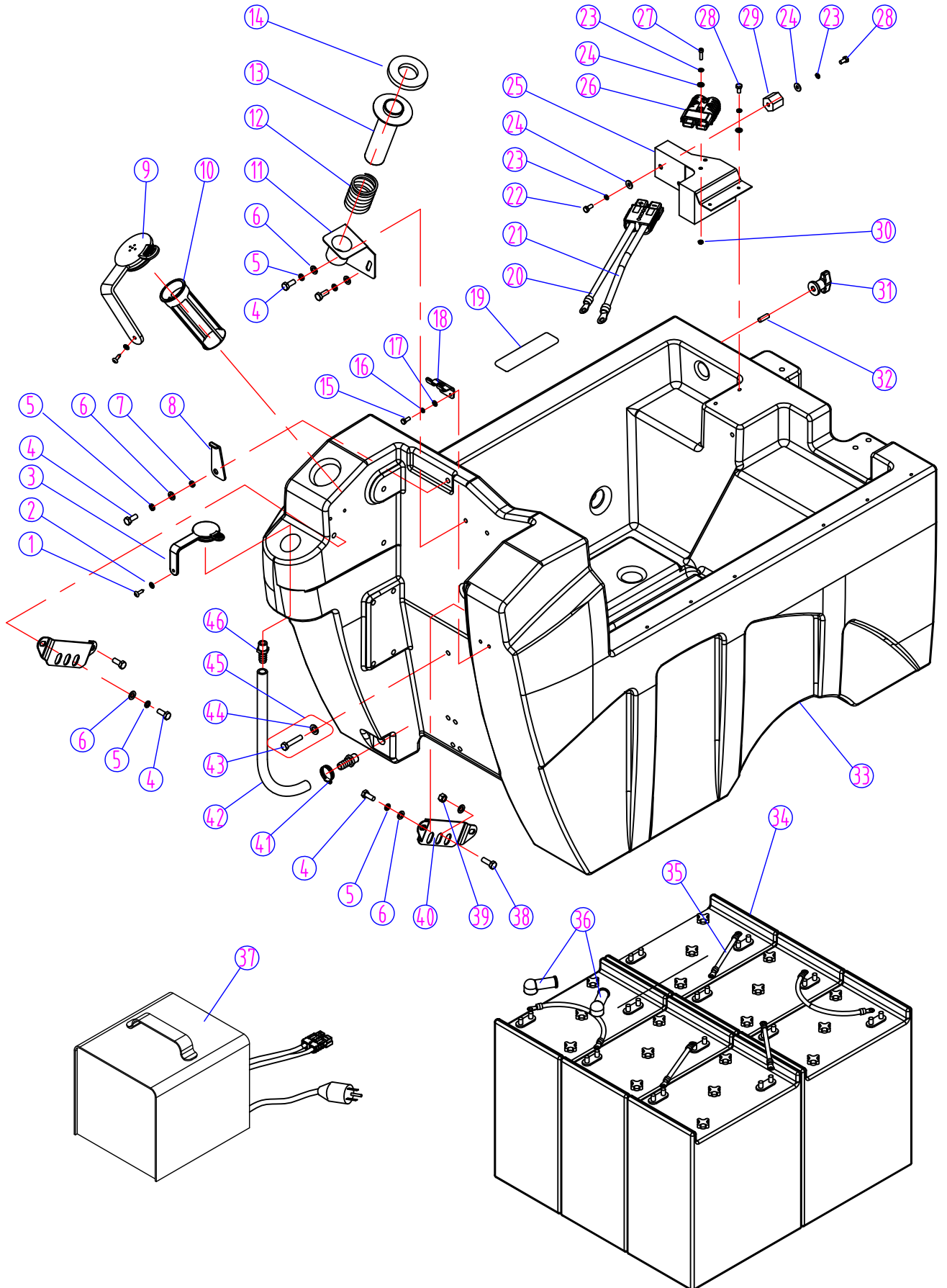

FANG 32T - SOLUTION TANK ASSEMBLY

DIA NO	PART NUMBER	DESCRIPTION	NO REQ'D
1	VA13477	SCREW, SELF-TAPPING, ST, M4 X 16	4
2	VV13664	WASHER, PLAIN, M4 X M12 X 1	2
3	VF82154	EXPANSION PLUG	1
4	VV13604	SCREW, M8 X 20	8
5	VF13519	WASHER, LOCK, M8	8
6	VF13535	WASHER, PLAIN, M8 X M20 X 2	8
7	VF81406	BUSHING	1
8	VF81404	SUPPORT, RECOVERY TANK	1
9	VF46454	FILTER, INTAKE TANK	1
10	VF84340	PLUG, EXPANSION	1
11	VF82029A	BRACKET, VAC TUBE	1
12	VF82032	SPRING	1
13	VF82030	ADAPTER, TUBE	1
14	VF82031A	GASKET, TUBE ADAPTER	1
15	VF14230	SCREW, M5 X 16	2
16	VV13601	WASHER, LOCK, M5	2
17	VF13532	WASHER, PLAIN, M5 X M11 X 2	2
18	VF84140	BRACKET, DRAIN HOSE	1
19	VF82123	DECAL	1
20	VF84135	WIRE, #4 X 600, RED	1
21	VF84148	WIRE, #4 X 600, BLACK	1
22	VF14232	SCREW, M6 X 10	2
23	VV13607	WASHER, LOCK, M6	8
24	GT13032	WASHER, PLAIN, M6 X M16 X 1.5	8
25	VF84109	BRACKET	1
26	VF81306G	CONNECTOR, GREY, 175A	2
27	VF13633	SCREW, M6 X 35	2
28	VF13495	SCREW, M6 X 16	4
29	VF81715	STANDOFF	2
30	VF13502	NUT, LOCK, M6	2
31	VA85003	KNOB, M8	4
32	VF84111	SCREW, M8 X 35	4
33	VF84101	SOLUTION TANK	1
34	VF84127	BATTERY, 6V, 305AMP HOUR	6
35	VF84132	CABLE, BATTERY	5
36	VF81724	CAP, BATTERY, BLACK	2
	VF81724R	CAP, BATTERY, RED	2
37	VF84128	CHARGER, 36V, 30AMP	1
38	VF14234	SCREW, M8 X 16	2
39	VF13513	NUT, M8	2
40	VF81408	PLATE, LOCK	2
41	VF82090	CLAMP (16-25)	1
42	VF83138	TUBING	1
43	VF14248	SCREW, M8 X 100, OPTIONAL	1
44	VA13516	WASHER, PLAIN, M10 X M30 X 1.5, OPTIONAL	1
45	VF84224	PU BLADES & FASTEN KIT, OPTIONAL	1
46	VF84137	HOSE BARB, G 1/2	2

FANG 32T - RECOVERY TANK ASSEMBLY

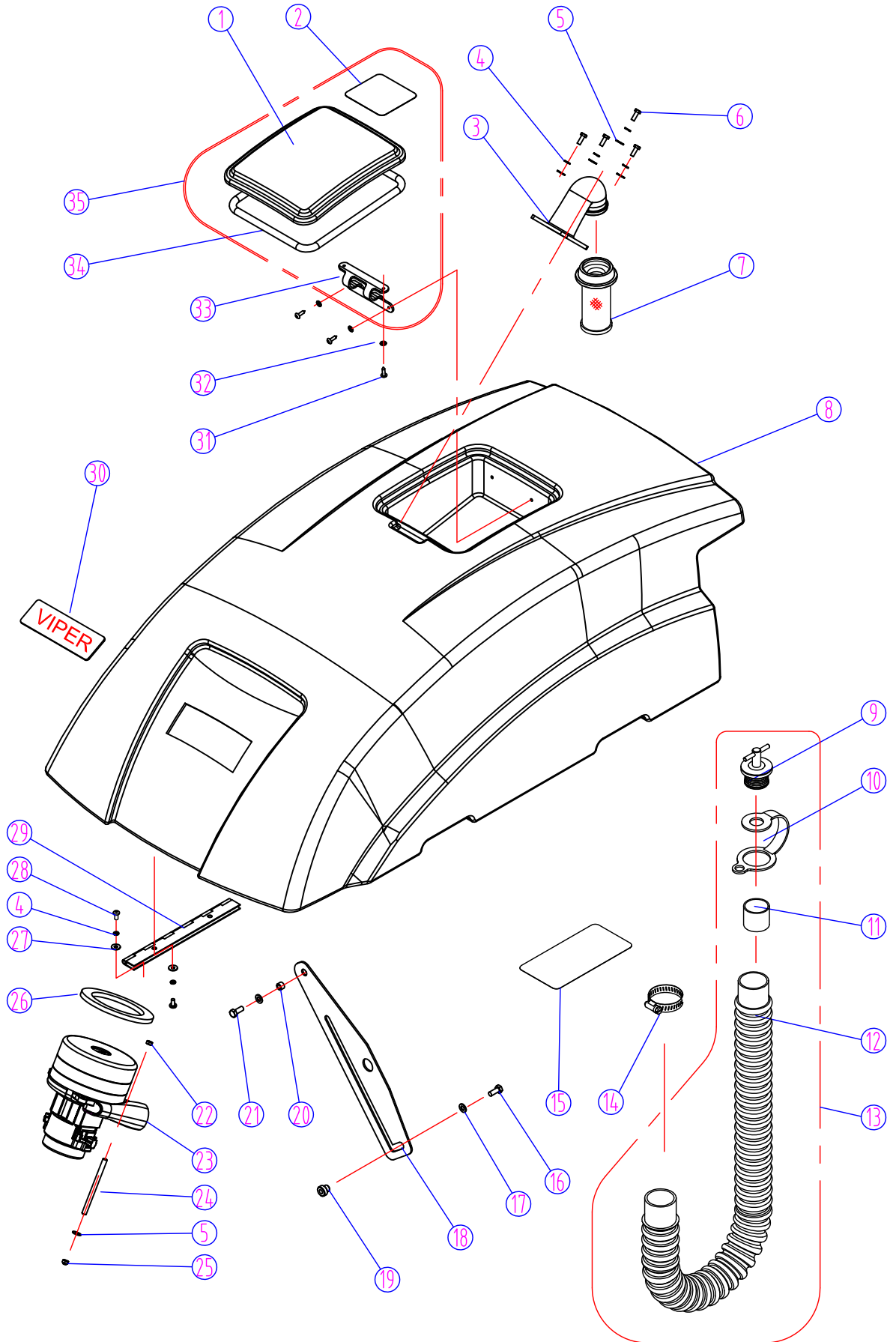

FANG 32T - RECOVERY TANK ASSEMBLY

DIA NO	PART NUMBER	DESCRIPTION	NO REQ'D
1	VF82010	CLEAR COVER, RECOVERY TANK	1
2	VF82083	DECAL, BATTERY WARNING	1
3	VF82009	ELBOW ADAPTOR, FLOAT	1
4	VV13607	WASHER, LOCK, M6	14
5	VF13533	WASHER, PLAIN, M6 X M16 X 2	7
6	VF14233	SCREW, M6 X 20	4
7	VF81504	FLOAT	1
8	VF84102	RECOVERY TANK (32")	1
9	VF81509	EXPANSION PLUG	1
10	VF81510-9	STRAP, DRAIN HOSE	1
11	VF81510-2	SLEEVE, DRAIN HOSE	1
12	VF81510-1	DRAIN HOSE	1
13	VF81510A	DRAIN HOSE ASSEMBLY	1
14	VV10113	CLAMP, 2"	2
15	VF84124	DECAL, BATTERY INSTALLATION	1
16	VF14235	SCREW, M8 X 35	1
17	VF13535	WASHER, PLAIN, M8 X M20 X 2	2
18	VF84107	BRACKET, DROP ARM	1
19	VF84133	BUSHING	1
20	VF84216	BUSHING	1
21	VA13491	SCREW, M8 X 25	1
22	VF13521	NUT, M6	3
23	ZD60000	MOTOR, VACUUM, 3 STAGE, 36VDC	1
24	VF81508	STUD (24")	3
25	VF13502	NUT, LOCK, M6	3
26	VF81503	SEAT	1
27	GT13032	WASHER, PLAIN, M6 X M16 X 1.5	10
28	VF14200	SCREW, M6 X 16	10
29	VF84113	HINGE, RECOVERY TANK	2
30	VF83143	LOGO (32")	1
31	VA13477	SCREW, SELF-TAPPING, ST, M4 X 16	4
32	VV13664	WASHER, PLAIN, M4 X M12 X 1	4
33	VF82010A	RUBBER HINGE	1
34	VF82010B	GASKET	1
35	VF82010-X	KIT, LID	1

FANG 32T - SCRUB HEAD ASSEMBLY

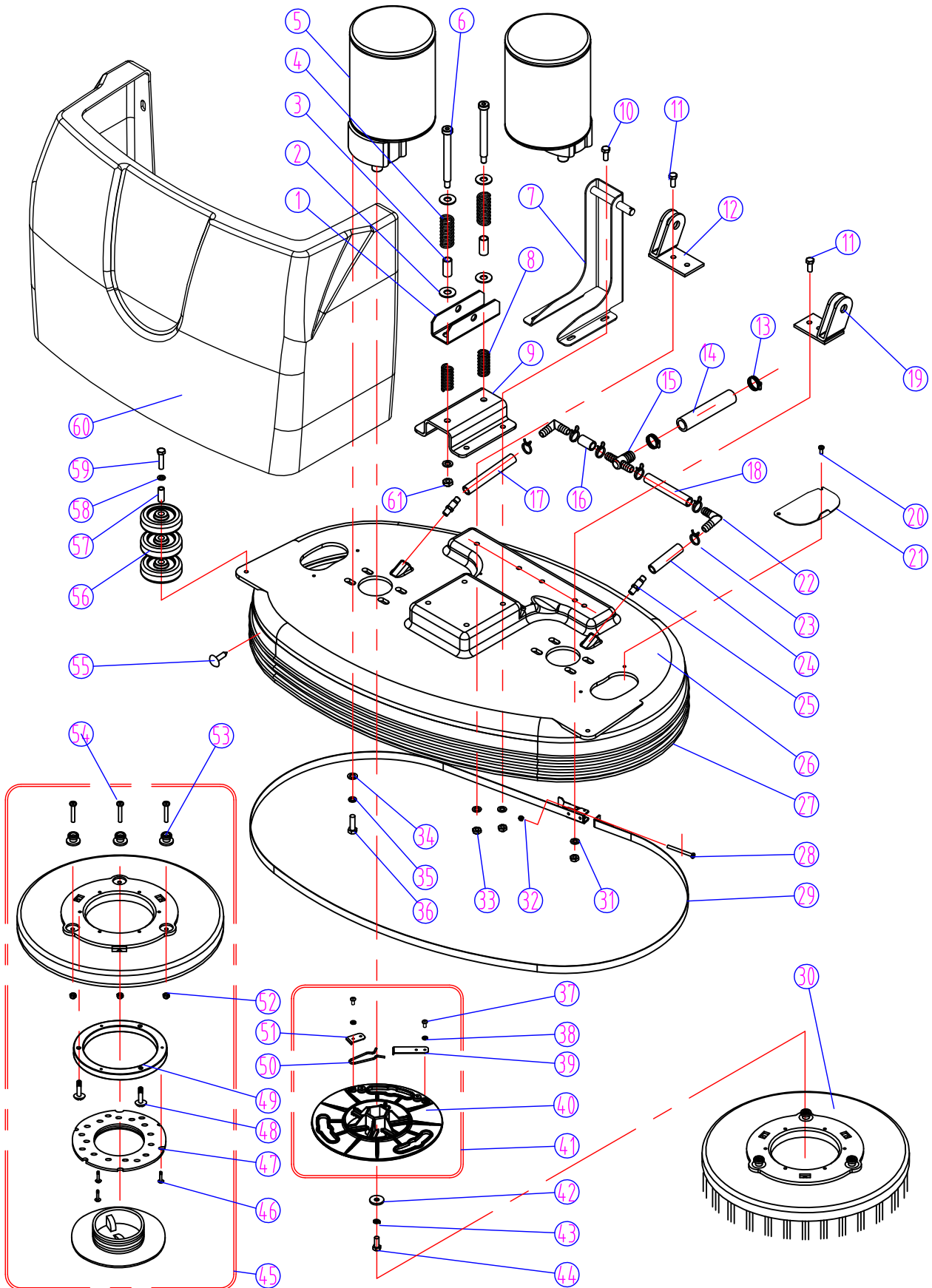

FANG 32T - SCRUB HEAD ASSEMBLY

DIA NO	PART NUMBER	DESCRIPTION	NO REQ'D
1	VF84315	BRACKET, SPRING	1
2	VF13615	WASHER, PLAIN, M13 X M30 X 2	4
3	VF84312	SLEEVE	2
4	VF84313	SPRING	2
5	ZD11000	BRUSH, MOTOR, 36VDC, 1HP	2
	ZD45407	KEY, 6.35 X 25	2
6	VF84311	BOLT, SHOULDER, 1/4" X 4.25" X 3/8"	2
7	VF84335	BRACKET, BRUSH LIFT	1
8	VF84314	SPRING	2
9	VF84304	BRACKET, SPRING MOUNT	1
10	VF14235	SCREW, M8 X 35	4
11	VA13491	SCREW, M8 X 25	5
12	VF84305A	BRACKET, LIFT, RIGHT	1
13	VF82090	CLAMP, (16-25)	2
14	VF84333	TUBING, 17.5mm ID, 145mm	1
15	VF84141	HOSE BARB, TEE	1
16	VF84334	TUBING, 11.5mm ID, 135mm	1
17	VF84345	TUBING, 11.5mm ID, 125mm	1
18	VF84346	TUBING, 11.5mm ID, 275mm	1
19	VF84303	BRACKET, LIFT, LEFT	1
20	VV20509	SCREW, M5 X 10	4
21	VF84325	DOOR, SCRUB HEAD	2
22	VF82042	ELBOW	2
23	VF82148	CLAMP, 16mm	6
24	VF82138	TUBING, 11.5mm ID, 75mm	1
25	VF84146	HOSE BARB	2
26	VF84302	COVER, SCRUB HEAD	1
27	VF84323	SKIRT, SCRUB HEAD	1
28	VF14310	SCREW, M5 X 70	1
29	VF84324	CLAMP, SKIRT	1
30	VF84330	BRUSH, 15 INCH	2
31	VF13542	WASHER, PLAIN, M8 X M20 X 2	9
32	GT13022	NUT, LOCK, M5	1
33	VF13503	NUT, LOCK, M8	8
34	VF13537	WASHER, PLAIN, M10 X M26 X 2	8
35	VV13620	WASHER, LOCK, 3/8"	8
36	VF14242	SCREW, 3/8"-1"	10
37	VF13545	SCREW, SELF-TAPPING, ST, M5 X 10	8
38	VV13601	WASHER, LOCK, M5	8
39	VF83134	STOP, DRIVE RELEASE	2
40	VF83130	PLATE, DRIVE	2
41	VF83130A	PLATE, DRIVE, ASSY	1
42	VF82058	WASHER	2
43	VV20298	WASHER, LOCK, 5/16"	2

FANG 32T - SCRUB HEAD ASSEMBLY

DIA NO	PART NUMBER	DESCRIPTION	NO REQ'D
44	VF14241	SCREW, 5/16" - 1"	2
45	VF84329	PAD DRIVE, 15 INCH	2
46	VA13484	SCREW, SELF-TAPPING, ST, M4 X 12	6
47	VF99003A	BIG MOUTH	2
48	MF-VF002-4A	SCREW, SELF-TAPPING, 1/4" - 1"	6
49	VF83118	SPACER	2
50	VF83132	SPRING	2
51	VF83131	CLAMP, BRUSH PLATE	2
52	VF13502	NUT, LOCK, M6	6
53	VF83133	STUD	6
54	VF14225A	SCREW, M6 X 40	6
55	VF84134	PUSH SCREW	7
56	VF82013	WHEEL, 3"	6
57	VF82055	BUSHING	6
58	VF13514A	WASHER, PLAIN, M8 X M16.5 X 1	6
59	VF14248	SCREW, M8 X 100	2
60	VF84104	COVER, FRONT	1
61	VF84326	NUT, LOCK, 3/8"	2

PARTS LIST

FANG 32T - SQUEEGEE AND SQUEEGEE LIFT ASSEMBLY

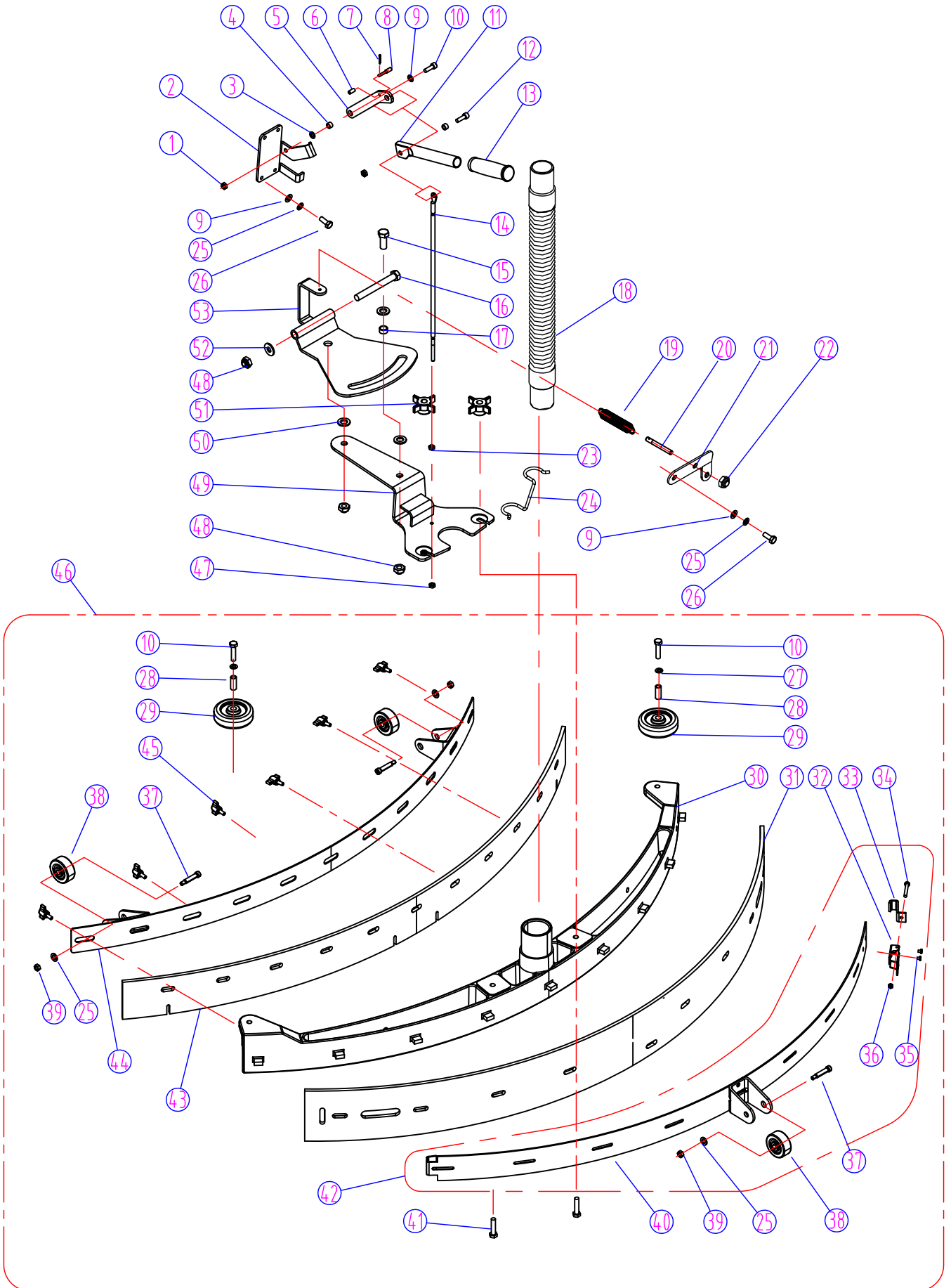

FANG 32T - SQUEEGEE AND SQUEEGEE LIFT ASSEMBLY

DIA NO	PART NUMBER	DESCRIPTION	NO REQ'D
1	VF13503	NUT, LOCK, M8	2
2	VF84220	BRACKET, SQUEEGEE LIFT	1
3	VF13514	WASHER, PLAIN, M8 X M16.5 X 1.5	1
4	VF84222	BUSHING	2
5	VF84218	ARM, SQUEEGEE LIFT	1
6	VF82159	BUSHING	1
7	VF14096	PIN, M2 X 20	1
8	VF82158	SHAFT	1
9	VF13535	WASHER, PLAIN, M8 X M20 X 2	6
10	VF14235	SCREW, M8 X 35	1
11	VF84217	HANDLE, LIFT	1
12	VA13491	SCREW, M8 X 25	1
13	VF48310	GRIP, HANDLE	1
14	VF84219	CABLE, SQGEEGEE, LIFT (32")	1
15	VF14238	SCREW, M12 X 30	2
16	VF13637	SCREW, M12 X 130	1
17	VF82016A	BUSHING	2
18	VF84223	HOSE	1
19	VF83144	SPRING	1
20	VF82047	SHAFT	1
21	VF83125	BRACKET, SPRING	1
22	VF13513	NUT, M8	1
23	VF13521	NUT, M6	1
24	VF83150	HOLDER,"U" HOSE	1
25	VF13519	WASHER, LOCK, M8	4
26	VV13604	SCREW, M8 X 20	4
27	VF13514A	WASHER, PLAIN, M8 X M16.5 X 1	2
28	VF82055	BUSHING	2
29	VF82013	WHEEL, 3"	2
30	VF84202	HOUSING, SQUEEGEE (FANG 32T)	1
31	VF84208	BLADE, SQUEEGEE, REAR, PU (FANG 32T)	1
32	VF81218	LATCH, HOOD	1
33	VF81209	HOOK, REAR SQUEEGEE BACKUP ADJUSTMENT	1
34	VF14310	SCREW, M5 X 70	1
35	VF81208	RIVET, M4 X 5	2
36	GT13022	NUT, LOCK, M5	1
37	VF81222	BOLT, SHOULDER, 5/16" X 1.25"	3
38	VF81219	WHEEL, 2"	3
39	VV20203	NUT, LOCK, 5/16"	3
40	VF84206	BACKUP STRIP, SQUEEGEE, REAR (FANG 32T)	1
41	VF14236	SCREW, M8 X 40	2
42	VF84206A	KIT, BACKUP STRIP, SQUEEGEE	1
43	VF84207	BLADE, SQUEEGEE, FRONT, PU (FANG 32T)	1
44	VF84205	BACKUP STRIP, SQUEEGEE, FRONT (FANG 32T)	1
45	VF82121	KNOB, M6	6
46	VF84200	SQUEEGEE ASSEMBY (FANG 32T)	1
47	VF13502	NUT, LOCK, M6	1
48	VF13501	NUT, LOCK, M12	3
49	VF84204	BRACKET, SQUEEGEE, MOUNT	1
50	VF13539	WASHER, PLAIN, M12 X M32 X 2	4
51	VF81210	KNOB, M8	2
52	VF13538	WASHER, PLAIN, M12 X M26 X 2	1
53	VF84214	MOUNT, PIVOT	1

FANG 32T - SOLUTION CONTROL ASSEMBLY

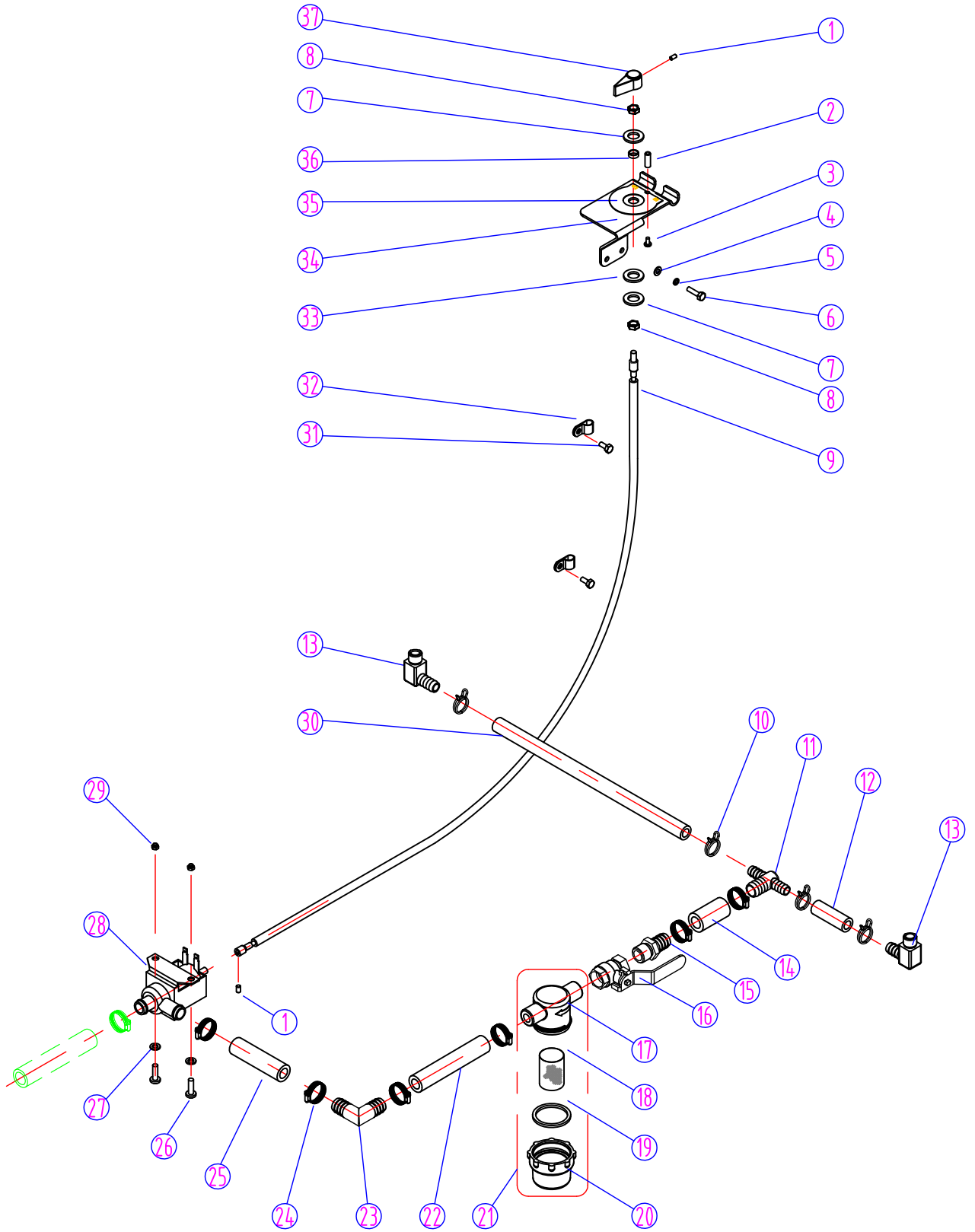

FANG 32T - SOLUTION CONTROL ASSEMBLY

DIA NO	PART NUMBER	DESCRIPTION	NO REQ'D
1	VF14245	SCREW, M5 X 6	2
2	VF82036	SHAFT	1
3	VV13650	SCREW, M4 X 10	1
4	VF13532	WASHER, PLAIN, M5	2
5	VV13601	WASHER, LOCK, M5	2
6	VF14230	SCREW, M5 X 15	2
7	VF13536	WASHER, PLAIN, M9.8 X M16 X 1	2
8	VF82075	NUT, 3/8"	2
9	VF84123	CABLE, SOLENOID	1
10	VF82148	CLAMP, 16mm	4
11	VF84141	HOSE BARB, TEE	1
12	VF84333	TUBING, 11.5mm ID, 125mm	1
13	VF81403A	ELBOW, SOLUTION TANK	2
14	VF84341	TUBING, 17.5mm ID, 50mm	1
15	VF84142	CONNECTOR, NPT 1/2"	1
16	VF84144	BALL VALVE, 15mm DN, NPT 1/2"	1
17	VF82168-3	SEAT, FILTER	1
18	VF82168-4	SCREEN, 80SS, FILTER	1
19	VF82168-5	GASKET, FILTER	1
20	VF82168-2	COVER, FILTER	1
21	VF82168	FILTER, ASSY	1
22	VF84347	TUBING, 17.5mm ID, 185mm	1
23	VF84143	ELBOW	1
24	VF82090	CLAMP	6
25	VF84342	TUBING, 17.5mm ID, 150mm	1
26	VF13495	SCREW, M6 X 16	2
27	VF13533	WASHER, PLAIN, M6 X M16 X 2	2
28	VF84120A	SOLUTION VALVE SOLENOID, 36VDC	1
29	VF13502	NUT, LOCK, M6	2
30	VF84348	TUBING, 17.5mm ID, 350mm	1
31	VV20509	SCREW, M5 X 10	2
32	VF81118	CLAMP	2
33	VF13540	WASHER, WAVE, M12	1
34	VF82037	BRACKET, DRAIN HOSE & VALVE	1
35	VF82069	LABEL, VALVE	1
36	VF82074	BUSHING	1
37	VF82038	KNOB, VALVE ADJUST	1

FANG 32T - CONTROL HOUSING

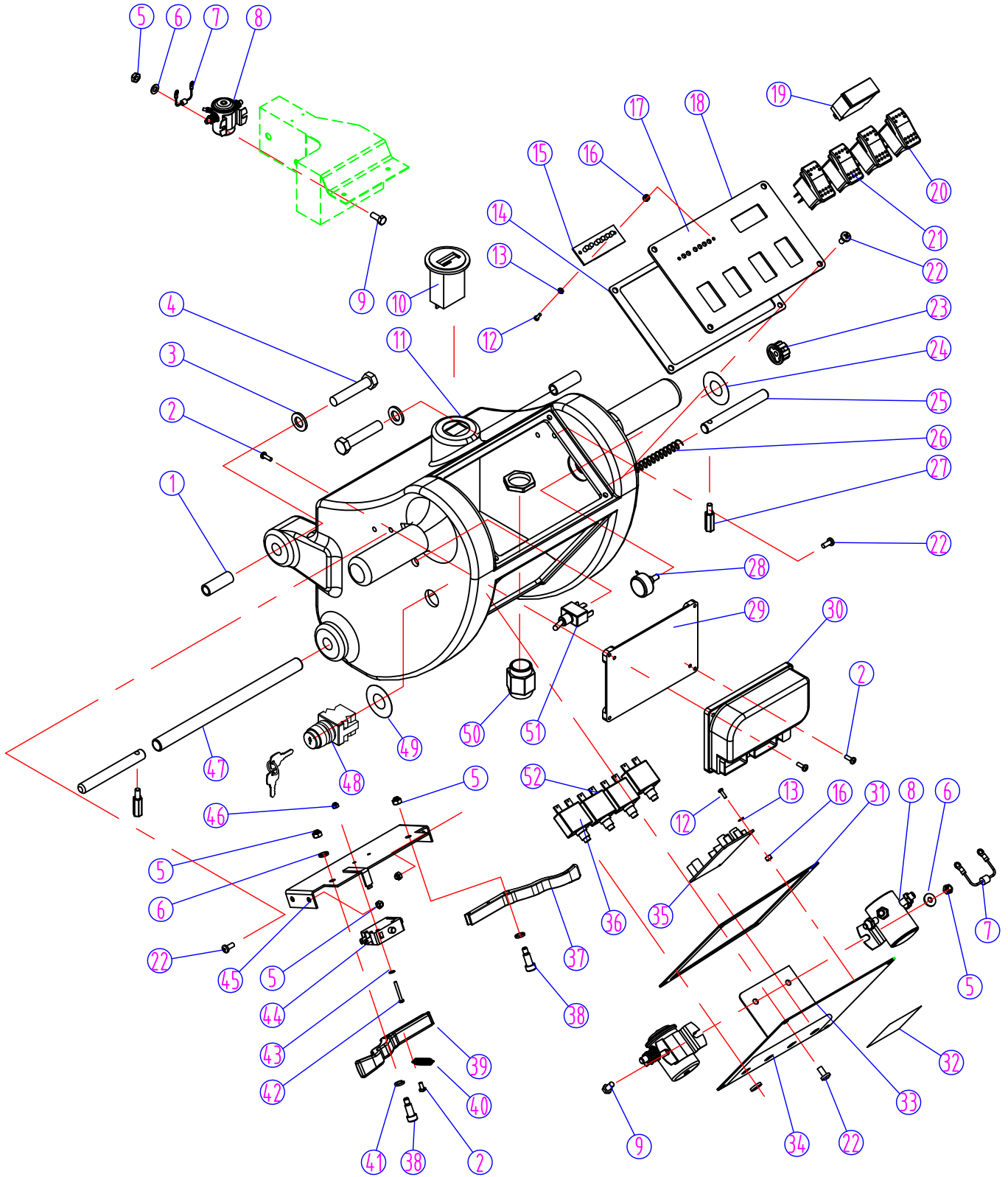

FANG 32T - CONTROL HOUSING

DIA NO	PART NUMBER	DESCRIPTION	NO REQ'D
1	VF84703	BUSHING	2
2	VF13491	SCREW, M4 X 12	7
3	VF14122	WASHER, PLAIN, M10 X M20 X 2	2
4	VF14121	SCREW, M10 X 65	2
5	VF13502	NUT, LOCK, M6	10
6	GT13032	WASHER, PLAIN, M6	6
7	VF81781	DIODE, 400V	3
8	VF84716A	SOLENOID, 36V	3
9	VF13495	SCREW, M6 X 16	12
10	VF84145	TIMER	1
11	VF84701	HOUSING, CONTROL	1
12	VF14078	SCREW, M3 X 10	6
13	VA50477	WASHER, PLAIN, M3 X M10 X 1	6
14	VF84711	GASKET	1
15	VF84717	LIGHTS, BATTERY CAPACITY	1
16	VF81719	SPACER	6
17	VF84702	LABEL, SWITCH (FANG 32T)	1
18	VF84704	PANEL, SWITCH (32")	1
19	VF81727	GAUGE, BRUSH PRESSURE	1
20	VF81725	SWITCH, BRUSH LIFT	1
21	VF84722	SWITCH, LIGHTED ROCKER	3
22	VF14200	SCREW, M6 X 16	12
23	VF81730	KNOB, SPEED CONTROL	1
24	VF82305	LABEL, SPEED CONTROL	1
25	VF84710	PIN, HANDLE LOCK	2
26	VF81716	SPRING	1
27	VF81710	PIN, HANDLE ADJUSTMENT	2
28	VF81729	POTENTIOMETER, 4.7K	1
29	VF84718	PLATE	1
30	VF84719	BOARD, SPEED CONTROL	1
31	VF84712	LABEL, CIRCUIT BREAKER	1
32	VF84713	SERIAL TAG	1
33	VF84705	PANEL, CONTROL HOUSING	1
34	VF84715	LABEL, CIRCUIT BREAKER	1
35	VF84723	CONTROL BOARD, BATTERY CAPACITY	1
36	VF99012	BREAKER, CIRCUIT, 12 AMP	1
37	VF84708	HANDLE, RIGHT	1
38	VF81711	BOLT, SHOULDER, M8 X 15 X M6	2
39	VF84707	HANDLE, LEFT	1
40	VF81712	SPRING	1
41	VF13514A	WASHER, PLAIN, M8 X M16.5 X 1	2
42	VF14212	SCREW, M3 X 25	2
43	VF13511	WASHER, TOOTH, M3	2
44	VF44203	SWITCH ASSEMBLY	1
45	VF84706	BRACKET, SWITCH (32")	1
46	VV13652	NUT, LOCK, M3	2
47	VF84709	TUBE, HANDLE, ADJUSTMENT	1
48	VF82153	KEY SWITCH	1
49	VF82160	LABEL, KEY SWITCH	1
50	VF84721	CORD STRAIN RELIEF	1
51	VF81722	SWITCH, TOGGLE	1
52	VF81734	BREAKER, CIRCUIT, 35 AMP	3

FANG32T WIRING DIAGRAM

BATTERY CAPACITY LIGHTS

