

Operator's Manual

Signature Series



WARNING

READ & UNDERSTAND OPERATOR'S MANUAL BEFORE USING THIS MACHINE



This symbol is used throughout this manual to warn of hazards or unsafe practices which could result in personal injury to yourself or others.

This manual is furnished with each new propane powered Tracker machine. It provides necessary operation and maintenance instructions. Read and understand the information in this manual before operating or servicing this machine.

- Check fuel cylinder for overfill before taking it into the building or placing in storage.
- Install fuel cylinder in a well ventilated place.
- Be aware of possible leaks of propane gas if odor is present.
- Check carburetor air filter for cleanness before starting engine.
- Never run engine with throttle in choke position.
- Never allow water to contact hot engine.
- Never leave the machine unattended while engine is running.
- Remove fuel cylinder and store outside in an approved cabinet.
- Secure fuel cylinders when being transported. If installed on the machine service valve must be OFF.
- Never store fuel cylinders in your van where they may be exposed to high temperatures.
- Maintain the machine as directed by the manufacturer.
- Only trained operators should be allowed to operate propane powered machines.

This publication is designed to provide accurate and authoritative information in regard to the subject matter covered. It is provided with the understanding that the publisher is not engaged in rendering legal or other professional services.

Table of Contents

<i>SAFETY PRECAUTIONS</i>	4
Before Operating the Machine.....	4
While Operating the Machine.....	4
Machine Storage.....	4
Servicing the machine.....	5
Additional Safety Concerns and Precautions.....	5
<i>MACHINE SET-UP</i>	6
Checking Oil Levels and Filters.....	6
Adjusting Handle Height.....	6
Installing the Fuel Cylinder.....	6
Installing or Removing Pad Driver and Pads.....	6
<i>MACHINE OPERATION</i>	7
Starting Machine.....	7
Operating Machine.....	7
Stopping the Machine.....	8
Emergency Stopping.....	8
Storing the Machine.....	8
Transporting the Machine.....	8
<i>MAINTENANCE</i>	9
Daily Maintenance - (every four hours of operation).....	9
Weekly Maintenance – (every 20 to 50 hours of operation).....	9
Monthly Maintenance – (every 80 hours of operation).....	9
Quarterly Maintenance – (every 250 hours of operation).....	10
Propane Fuel System.....	10
Changing the Oil.....	10
Checking the Oil Level.....	10
Adjusting Belt Tension.....	10
<i>PROPANE FUEL CYLINDERS</i>	11
Checking a cylinder for overfill.....	11
<i>TROUBLESHOOTING</i>	12
<i>WARRANTY INFORMATION</i>	13
Instructions and conditions for warranty reimbursement.....	14
Engine Warranty - Allowed Labor Hours.....	15

Safety Precautions

- This propane fueled machine is intended for commercial use only. It is designed for floor maintenance. Do not use the machine other than describe in this Operator's Manual.
- All operators must read, understand and practice the safety precautions in this section as well as the "Safety Awareness Manual" included in this manual.
- Only trained and authorized operators should operate propane powered floor machines.
-  Check fuel cylinders for overfill before taking them into the building or your van. (see Refilling Propane Fuel Cylinders).

Before Operating the Machine

- Check oil level.
- Check carburetor air filter.
- Check pad and pad holder.
- Adjust handle height.
- Install fuel cylinder in a well ventilated area.

While Operating the Machine

 Even though the 89 db sound level is below OSHA's PEL, it is the course of wisdom to wear hearing protection while operating any internal combustion engine in an enclosed area.

 If you smell the odor of propane, stop the engine, remove the cylinder and take it outside for inspection.

 Be aware of odors other than propane. Toxic emissions are produced by internal combustion engines. Properly maintained engines produce a small amount of these gasses including carbon monoxide. Although carbon monoxide has no odor, the hydrocarbons do and an elevation of odor may indicate increased CO as well.

 Do not allow the machine to run unattended except for short times while moving and obstruction.

 Exhaust parts are extremely HOT. Be careful not to allow them to come into contact with anything or anyone.

 Do not attempt to change pads while the engine is running.

Machine Storage

- Stop the engine by closing the service valve on the fuel cylinder.
- Remove the key from the switch, if applicable.
- Remove the fuel cylinder from the machine and store it outside in a secure approved cabinet (see "Propane Fuel Cylinders").
- Clean and inspect air and dust filters.

Servicing the machine

Preventive maintenance is the responsibility of the operator. It includes:

- Checking oil level
- Checking and cleaning air and dust filters.
- Keeping machine clean and lubricated
- Reporting any damaged or worn parts.
- See Maintenance section for servicing intervals and instructions.
- Servicing or adjusting the propane fuel system should only be done by a trained service technician.



Never attempt to adjust the fuel system of a propane engine! If equipped with an emission monitoring or controlling system never attempt to disconnect it or circumvent it!

Additional Safety Concerns and Precautions

- Operator must have completed training before using machine.*
- Sweep floor and check for items protruding out of the floor surface before starting.
- Never tilt the machine back while it is running.
- Do not start engine with the transport wheel attached.
- Exercise extreme caution when installing or changing abrasive media. The machine is very heavy!
- Check for loose bolts and nuts daily
- Clean carburetor air filters after four hours running and clean or replace daily before operation.
- Clean entire machine after each use including under the gear drive assembly.
- Because of the length of time these machines may operate continuously it is very important to be assured of proper ventilation.
- Do not stand on the machine.
- Check for wear on drive plates and flex hubs daily. Replace if damaged.
- Never attempt to bypass or disconnect the kill switch or any future safety devices.

* To arrange for operation and safety training contact STONEKOR LLC by phone at 770.773.3875
[email customerservice@stonekor.com](mailto:customerservice@stonekor.com) or mail request to P.O. Box 443 ,Adairsville, GA 30103

Machine Set-Up

Checking Oil Levels and Filters

Check oil levels prior to starting engine. **Do not screw dip stick in to check oil.** Refer to engine owner's manual for the proper procedure. **DO NOT OVERFILL OIL LEVEL;** to do so may cause damage to the engine and may elevate harmful emissions. Use 10W30 oil. Always check oil daily before using the machine (see "Daily Maintenance").



Be sure the carburetor air filter is free of dust, oil, etc. Dirty filters are the most frequent cause of elevated toxic emissions.

Check recoil dust filter. Clean or replace if necessary. See the instructions in the engine owner's manual.

Adjusting Handle Height

The machine is equipped with an adjustable handle for comfort and use. Most find it necessary to adjust the handle to "belt height" for optimum control. A 9/16 wrench is used to loosen and tighten the pivot points.

Installing the Fuel Cylinder

1. Take machine to well ventilated area.
2. Check cylinder for overfill (see "Refilling Propane Fuel Cylinder").
3. Place cylinder on the machine in tank holding area and secure the strap.
4. Connect fuel cylinder to the machine using the "Rego" connection. Tighten hand tight. Do not use a wrench or pliers or cross thread the Rego connection.
5. Open the service valve slowly. Be alert for the odor of propane that may indicate a leak.
6. To remove the cylinder, reverse the procedure.

Installing or Removing Pad Driver and Pads

Consult an authorized distributor to assist you in selecting the correct pad for your specific needs.

Pad Driver Installation:

1. Tilt machine on the right side (dip stick down).
2. Place pad driver on drive shaft and spin pad driver clockwise to install.

Pad Removal & Installation:

1. Tilt machine back on rear caster or service position.
2. Remove center-lock from pad driver.
3. Center new pad on pad driver and secure with center-lock ring.

Pad Driver Removal:

1. Apply downward pressure on bell of machine deck.
2. Use ¾" open end wrench on top of drive shaft exposed on top of deck.
3. Strike the wrench with a rubber mallet to break loose the shaft from the pad driver. (Counterclockwise)
4. Remove pad driver by spinning it off counterclockwise.

Machine Operation

Starting Machine

1. Check fuel cylinder for overfill (see “Refilling Propane Fuel Cylinder”).
2. Install cylinder on machine.
3. Place machine on level surface and check for correct oil level.
4. Tilt machine back on rear caster.
5. Slowly open the service valve on the fuel cylinder.

NOTE: Opening the service valve too quickly may cause the excess flow valve to stop the flow of propane. If this occurs, close the valve, wait a few seconds and re-open the valve **SLOWLY!**

6. If the machine is supplied with a power cord, plug cord into 110 volt outlet. Use necessary precautions when using electricity.
7. Push the throttle lever to the choke position and engage the starter (either by turning the key switch to start or depressing the start button). Do not engage the starter for more than 20 seconds at a time. Allow 10-20 seconds between attempts to start the engine.
8. When engine starts, ease the throttle back to running position.

NOTE: *Do not run engine with the throttle in the choke position! Excessive harmful emissions will be produced putting you in harm's way!*

9. Increase throttle to about $\frac{3}{4}$ and carefully lower the machine pad to the floor while walking forward slowly.

Operating the Electric Clutch (if equipped) - engages pad driver

1. Move the throttle to slow and squeeze the “trigger switch” on the operation handle.
2. Move the throttle to $\frac{3}{4}$ speed, slowly lower the pad to the floor while walking forward slowly.

CAUTION: Never engage clutch in the fast run position or with the pad on the floor, this may cause damage to the clutch and the floor!

Operating Machine



WARNING! Be careful not to allow the machine to come in contact with loose tiles or other obstructions on the floor. The pad is turning at about 2000 RPM. If objects are hit by the revolving pad they could become dangerous missiles.

1. Keep machine moving. Running in one place for more than a few seconds may damage the floor.
2. Do not leave machine unattended while the engine is running for long periods of time. If necessary to leave the machine for short periods, move the throttle lever to the idle position and tip machine back on the rear caster.



ATTENTION: It is possible to damage the engine by allowing it to idle for long periods of time by affecting proper lubrication.



WARNING! Exhaust emissions contain harmful toxic gasses; the worst being carbon monoxide. Always make certain that adequate ventilation is available. Do not operate the machine in confined areas for prolonged times.

3. It has been the accepted practice to start buffing from the right side of the aisles.

Stopping the Machine

1. Put machine in idle mode.
2. Close the service valve on the fuel cylinder while the engine is running. This serves to “purge” the fuel system of all flammable gas.
3. Tilt the machine back on its rear caster and allow the engine to run until it stops.
4. Turn the key switch to OFF if equipped.

Emergency Stopping



In case of emergency, the machine can be brought to an instant stop by the following methods:

Release “KILL SWITCH”.

Storing the Machine

1. Remove the fuel cylinder and store in properly propane storage cage outside (see Propane Fuel Cylinders).
2. After the engine has cooled completely, clean machine thoroughly.
3. Perform all daily maintenance requirements.
4. Store machine in a cool, dry, secure area where it will not be damaged by other traffic.
5. Tilt the machine back on the rear caster with the pad off the floor.

Transporting the Machine

- When transporting the machine from one job to another, secure the machine with the fuel cylinder installed and the service valve OFF!
- Allow the engine to cool down before loading it.

Maintenance



WARNING: Before attempting any maintenance procedures on the machine, close the service valve on the fuel cylinder and stop the engine.

Repairs and adjustments to the fuel system must be made by an authorized, properly trained service technician. To keep the machine in good working condition, simply follow the daily, weekly and monthly maintenance procedures.

Keeping the machine clean and free from accumulated dust, lint and oil allows free air flow across the engine to cool properly. Always use clean recoil dust filters. These can be cleaned by washing them in a flow of water and shaking them dry. Extra filters may be ordered from Stonekor at 800.633.0519. Keep a log book of maintenance and/or repairs.

Daily Maintenance - (every four hours of operation)

- Check oil level (use 10W30 or SAE30 oil only).
- Check recoil dust filter.
- Check and clean carburetor air filter.
- Check belt tension by pinching belt together. Belt should deflect only ½” (13 mm).
- Make sure all components (pad holder, fuel cylinder, etc.) are secure and tight.
- Check pad holder and pad daily (clean or replace).
- Clean machine. If compressed air is available, blow dust from machine and engine, concentrating on the inside of engine shrouds. Wash undercarriage.
- Clean dust collection bag.

CAUTION: Care should be taken to make sure engine is cool before water is used to prevent warping and other damage.

Weekly Maintenance – (every 20 to 50 hours of operation)

- All Daily Maintenance services.
- Change oil and oil filters at 50 hours of service. Use 10W30 or SAE30 motor oil. Use of non-recommended oil may void the engine warranty (see engine owner’s manual).
- Check for loose nuts and/or bolts on entire machine.
- Examine all propane fuel components for leaks or wear. Replace if necessary.
- Grease wheels. Use one pump only of white lithium grease. More grease than recommended may push the seals and dust covers out, allowing dust and other foreign materials to penetrate the bearings, thus shortening their life, as well as allowing grease to drop from the wheels to the floor.

Monthly Maintenance – (every 80 hours of operation)

- Perform all Daily and Weekly Maintenance services.
- Consult engine owner’s manual for the following:
 - Torque head bolts.
 - Check valve clearance.
 - Torque valve cover bolts.
 - Inspect spark plugs. Replace if necessary.
 - Remove engine shroud and clean cooling fins.

Quarterly Maintenance – (every 250 hours of operation)

- Perform all monthly maintenance items.
- Have engine checked by an Authorized Service Center. Including emissions check.

Propane Fuel System

Repairs and adjustments to the fuel system can only be made by an authorized, properly trained and certified service technician. Improper adjustments will cause increased toxic emissions of carbon monoxide and may result in carbon monoxide poisoning.



Changing the Oil

1. The engine manufacturer recommends 10W30 or SAE30 motor oil.
2. Run engine for five minutes to warm the oil.
3. Make sure machine is on a level surface, with pad resting on the floor. Place a container under the drain and open the oil drain valve. Allow oil to drain completely.
4. Close drain valve and add 1 quart of 10W30 or SAE30 motor oil. Check level and add if necessary.
5. Replace oil-fill cap assembly. Hand tighten only.

ATTENTION: Do not over fill oil and never run engine with low oil level.

Checking the Oil Level

When checking oil, remove dip stick, wipe clean, and then reinsert the dip stick into the engine. **DO NOT SCREW IN.** Remove dip stick and observe oil level as indicated on the dip stick.

Adjusting Belt Tension

Tools required:

- $\frac{3}{4}$ " (19 mm) open end wrench
- $\frac{15}{16}$ " (24 mm) deep-well socket

1. Loosen Mounting Bolt on top side of machine deck while holding adjusting nut on underside of deck.

NOTE: The mounting bolt must be loosened before adjustment can be made.

2. Rotate adjusting nut counter clockwise with socket to apply tension to belt.
3. While holding the tension on the adjusting nut, tighten the mounting bolt on the top of the deck.
4. Check belt tension by pinching belt together. Belt should depress only $\frac{1}{2}$ " (12 mm).

Mounting Bolt

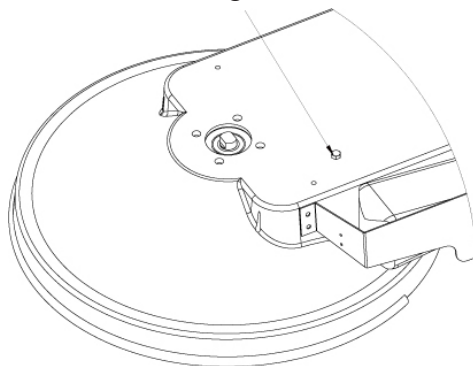

Adjusting Bolt

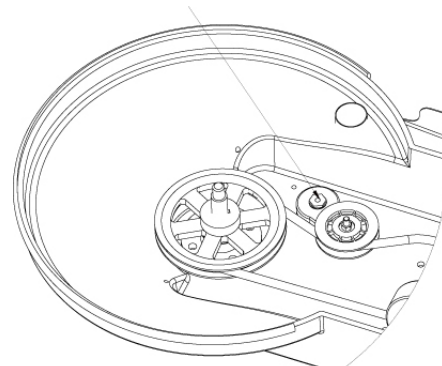

Propane Fuel Cylinders

The National Fire Protection Association (NFPA) has established standards for the storage and handling of liquefied petroleum gasses. This standard is NFPA58 and is recognized in the United States and Canada as well as some other countries. For other countries the owner must assure that the required regulations are met.

Liquefied propane will expand 270 times into flammable vapor, which is used as fuel for propane engines. Proper training is recommended for those operating propane powered machines in order to limit the hazards related to the handling and storage of propane fuel cylinders (see the “Safety Awareness Manual” section of the manual.

The fuel cylinder supplied with this machine is a D.O.T. 4E240 motor fuel cylinder. Cylinders not branded with D.O.T. 4E240 on the top collar should never be used on propane powered Eagle burnishing equipment. Never use a cylinder from a gas barbecue, for example, on this machine.

The capacity of the 4E240 cylinder is 20 lbs., 80% of the total liquid capacity. Never allow a fuel cylinder to be overfilled. Have the cylinder filled at a reputable propane dealer and check it for overfill before accepting it.

Checking a cylinder for overfill

Always wear frost proof gloves and a face shield before attempting to check fuel cylinder for overfill.

1. Take to a safe area outside, away from open flames and cigarettes.
2. Open the fixed liquid level gauge (bleeder valve).
3. Observe the gas exiting from the valve: white cloud = overfilled, no cloud visible = SAFE!
4. If overfilled, allow to vent until vapor is clear.

Do not attempt to repair a damaged propane cylinder yourself. Return the cylinder to your propane vendor for authorized service.

ATTENTION: Propane fuel cylinders, whether full or empty, should be stored outside the building in a secure approved cylinder storage cabinet in accordance with NFPA58. Remove cylinder from machine when not in use. Local authorities may have additional requirements for fuel cylinder storage. Always consult with the local fire marshal for local codes.

CAUTION: Propane fuel cylinders used on Eagle machines are VERTICAL cylinders and should always remain in the vertical position, even when being transported or stored. This position assures the pressure relief valve and other fittings are in direct contact with the vapor in the cylinder and not the liquid. Liquid escaping from the cylinder as the result of a leak or overfilling will expand to 270 times the volume of flammable vapor.

Troubleshooting

Problem	Cause	Solution
<i>Will not start</i>	No fuel or dirt in fuel line Blown head gasket Engine overload Dirty air cleaner Faulty spark plug Fuel system out of adjustment Defective ignition	See engine owners manual for servicing NOTE: Only properly trained Service Technicians should adjust or repair fuel systems!
<i>Hard to start</i>	No fuel or dirt in fuel line Engine overload Dirty air cleaner Faulty spark plug Spark plug or head bolts loose Blown head gasket Timing, coil or valves need adjusting Regulator needs adjustment Insufficient vacuum	See engine owners manual for servicing NOTE: Only properly trained Service Technicians should adjust or repair fuel systems!
<i>Lacks power</i>	Improper valve clearance Dirt in fuel line Faulty spark plug Improper oil level Worn rings	See engine owners manual for servicing NOTE: Only properly trained Service Technicians should adjust or repair fuel systems!
<i>Odor of burned rubber</i>	Belt out of adjustment	See "Adjusting Belt Tension"
<i>Engine overheats</i>	Incorrect oil level Engine overload Build up of dirt inside engine shroud	See engine owners manual for servicing
<i>High fuel consumption</i>	Faulty spark plug Dirty air cleaners Improper fuel system adjustment	See engine owners manual for servicing NOTE: Only properly trained Service Technicians should adjust or repair fuel systems!
<i>Engine stops suddenly</i>	Out of fuel Faulty spark plug Pad not centered on pad driver Incorrect pad size Low oil	Change fuel cylinders Clean, adjust/replace spark plug Center pad on pad holder Replace with proper pad Add oil (see Changing Oil notes)
<i>Excessive vibration</i>	Loose bolts on engine or deck Pad not centered or damaged pad Incorrect oil level Engine overloaded Dirty filters Faulty spark plug	Inspect and tighten all bolts Center or replace pad Check and adjust oil level See engine owners manual for servicing Clean or replace filters Check adjust/replace spark plug

Warranty Information

Subject to the conditions and expectations stated in this warranty, we warrant our products to be free from defects in material and workmanship, under normal use and service, for the periods listed, warranted to the original purchaser.

	90 days	1 year	2 years	3 years
Belts, Brushes, Choke Cables, Clutches, Electrical Components	X			
Filters, Hand Grips, Hoses, Pad Drivers, Starters, Switches	X			
Throttle Cables, Wheels	X			
Emissions Shutdowns, Gearboxes, Hydraulic Motors		X		
Lockoffs, Fuel Valves		X		
Engines: (Warranty covers Manufacturer's defects only)				
Robin EH65 22hp			X	
Kawasaki KH541 17 hp			X	
Frames, Handles, Pulleys, Regulators			X	
Tanks (LP)				X
Tank Valve		X		
Catalytic Muffler	Replace at 500 Hours			

At any time within the periods listed, the company will furnish STONEKOR product replacement parts. Such replacement parts will be furnished to the original owner and charged, including transportation charges, through an authorized Stonekor distributor FOB the factory (Georgia). ONLY when the original part is returned within 30 days and is found to be defective, the owner will be credited for the cost of the replacement part, labor (as specified in the Warranty Flat Rate Schedule) and normal transportation charges. Parts replaced or repaired under the warranty are fully guaranteed for the remainder of the original warranty period. Any implied warranty granted under State Law, including warranties or merchantability or fitness for a particular purpose are limited to duration to the express warranty granted hereunder. The manufacturer or manufacturer's authorized representative in no event shall be liable for direct, indirect, incidental or consequential damage. Abuse and failure to properly maintain engine is subject to void warranty. Proper engine maintenance includes filter and oil changes as described in the engine manufacturer's operator manual. See information on the Preventative Maintenance Kit at the end of the manual. Some states do not allow limitations on how long an implied warranty lasts and/or do not allow the exclusion or limitation of incidental damages, so the above limitations and exclusions may not apply to you. "THIS WARRANTY IS IN LIEU OF ANY OTHER WARRANTIES, EXPRESSED OR IMPLIED, INCLUDING ANY IMPLIED WARRANTY OF MERCHANTABILITY, FITNESS FOR A PARTICULAR PURPOSE, OR OTHERWISE. UNDER NO CIRCUMSTANCES WILL THE SELLER BE LIABLE FOR ANY LOSS, DAMAGE, EXPENSE, OR CONSEQUENTIAL DAMAGE ARISING IN CONNECTION WITH USE, OR INABILITY TO USE, SELLER'S PRODUCTS."

We reserve the right to make changes and improvements to our equipment without notice.

Please make sure to record this information. This information will be necessary to retrieve warranty information in the future.

Date purchased: _____/_____/_____

Model Number: _____

Serial Number: _____

Instructions and conditions for warranty reimbursement

Service Pre-Approved by STONEKOR

1. Call STONEKOR warranty department to file a claim. For warranty requests on equipment you will need to provide the Engine Serial Number, Machine Serial Number, Model Number, and Proof of Purchase (i.e. invoice)
2. You will be directed to the appropriate service organization based on where your business is located.
3. The service organization will arrange an onsite visit or specify the location to bring your equipment for repair.
4. You may be required to pay travel charges and service fees in advance of an onsite visit. The amount of these charges may vary depending upon the service organization and your geographic location.
5. The service technician will perform the necessary diagnostic and repair work and contact STONEKOR to determine if the defective component(s), travel charges, and service fees will be covered under the STONEKOR Warranty Policy.
6. The service technician will contact STONEKOR to acquire the necessary replacement parts and an RGA number for the return of the defective components. A copy of this RGA form will be faxed to you. (The RGA form will specify the carrier to use for parts to be returned).
7. STONEKOR will ship the replacement parts to you or the service rep. and invoice you at full value along with related freight charges.
8. Upon receipt of the returned goods you will be credited for the replacement parts invoice if the items are still under warranty. Please include a copy of the RGA form with the returned items.
9. Advance payment of travel and service fees determined to be covered under the STONEKOR Warranty policy will be reimbursed by the service organization involved. If warranty does not apply, charges will not be reimbursed.

Service Not Pre-Approved by STONEKOR

1. Call STONEKOR warranty department to file a claim. For warranty requests on equipment you will need to provide the Engine Serial Number, Machine Serial Number, Model Number, and Proof of Purchase (i.e. invoice)
2. You will also need to provide documentation for all repair related charges.
3. Your claim will be reviewed to determine if it is covered by our warranty policy. If approved, a Return Goods Authorization (RGA) number will be issued for defective parts and an RGA form will be faxed to you. (The RGA form will specify the carrier to use for parts to be returned)
4. We recommend that you place an order for the replacement parts that are needed. These will be invoiced to you at full value along with related freight charges.
5. If your warranty claim has been approved and an RGA number has been provided to you, you will be credited for the replacement parts invoice upon receipt of the defective parts. If the defective parts are not covered under warranty no credit will be issued.
6. Approved travel and service charges will also be credited to you upon receipt of the defective parts.

Warranty Conditions

1. Approved warranty return items must be received by STONEKOR within 30 days of the RGA date in order to receive credit.
2. A copy of the RGA form should be included with the items returned.
3. Replacement parts orders will be shipped via UPS or Fedex Ground. You will be responsible for any upgraded or expedited delivery charges. These additional charges will not be covered under warranty.
4. Warranty travel is limited to 60 miles and applies only to claims made within 30 days of the date of purchase. Our mileage reimbursement rate is \$0.35 per mile. (Rate is subject to change).
5. Labor hours are subject to the Stonekor Warranty Flat Rate Chart. (Rates are subject to change).
6. Warranty travel and service fees may be denied if not pre-approved and performed by an STONEKOR Authorized Service Organization.

Warranty Contacts

Customer Service 800.633.0519 customerservice@stonekor.com

Engine Warranty - Allowed Labor Hours

Engines covered : EH65V, FH541V

JOB DESCRIPTION	LABOR HOURS ALLOWED	JOB DESCRIPTION	LABOR HOURS ALLOWED
<u>MISC</u>		<u>RECOIL STARTER & GOVERNOR</u>	
DIAGNOSIS	0.5	RECOIL STARTER ASSY	0.1
<u>TUNE UP & ADJUSTMENT</u>		REEL, SPRING, OR ROPE	0.3
COMPRESSION MEASUREMENT (ALL)	0.4	GOVERNOR ASSY OR SLEEVE	1.0
VALVE CLEARANCE ADJUSTMENT (ALL)	0.6	GOVERNOR SHAFT OR OIL SEAL	0.9
VALVE CLEARANCE ADJUSTMENT (1 CYL)	0.3	GOVERNOR ARM	0.3
GOVERNOR ADJ (Includes Low Idle & High Speed Adj) (ALL)	0.3	CONTROL PANEL ASSY	0.3
LOW IDLE & HIGH SPEED ADJUSTMENT (ALL)	0.2	<u>AIR CLEANER / MUFFLER</u>	
CARB CLEANING (ALL)	0.7	AIR CLEANER CASE	0.2
<u>CYLINDER HEADS, VALVES, & CAMSHAFT</u>		AIR CLEANER ELEMENT OR COVER	0.1
CYLINDER HEAD COVER OR GASKET (1 CYL)	0.2	MUFFLER OR HEAT COVERS	0.2
CYLINDER HEAD COVERS OR GASKETS (ALL)	0.3	EXHAUST PIPE(S) OR GASKET(S)	0.3
CYLINDER HEAD (1 CYL)	1.7	<u>CARB, FUEL PUMP, & FUEL TANK</u>	
CYLINDER HEADS (ALL)	2.2	CARBURETOR	0.5
CYLINDER HEAD GASKET (1 CYL)	1.3	CARB HOLDER OR INTAKE MANIFOLD	0.6
CYLINDER HEAD GASKETS (ALL)	1.8	CHOKE VALVE(S) / THROTTLE VALVE(S)(Includes Carb R&R)	0.6
VALVE AND / OR SPRING (1 VALVE OR SPRING)	1.5	MAIN JET(S) FLOAT OR VALVE (Includes Carb R&R)	0.6
VALVE AND / OR SPRINGS (2 VALVES OR SPRINGS) (1 CYL)	1.6	FLOAT CHAMBER GASKET	0.3
VALVES AND / OR SPRINGS (ALL)	2.2	SOLENOID VALVE OR FUEL CUT VALVE	0.3
VALVE LAPPING OR VALVE GUIDE (1 VALVE, 1 CYL)	1.6	FUEL TUBE (To Carb)	0.2
VALVE LAPPING (2 VALVES, 1 CYL)	1.8	DIAPHRAGM FUEL PUMP	0.2
VALVE LAPPING OR VALVE GUIDES (ALL)	2.6	FUEL FILTER	0.1
CAMSHAFT	1.3	<u>IGNITION, COOLING, & STARTER MOTOR</u>	
ROCKER ARM OR PUSH ROD (1 ARM OR ROD)	0.4	ENGINE FLYWHEEL	0.7
ROCKER ARMS OR PUSH RODS (ALL)	0.6	CHARGING COIL OR STATOR	0.9
<u>CYLINDER/CRANKCASE & OIL PUMP</u>		IGNITION COIL (1)	0.5
CYLINDER BORING & HONING (1 CYL)	4.8	IGNITION COILS (ALL)	0.7
CYLINDER BORING & HONING (ALL)	5.3	SPARK PLUG (1)	0.1
CRANKCASE OR MAIN BALL BEARING	4.1	SPARK PLUGS (ALL)	0.2
BREATHER, BREATHER COVER, OR REED VALVES	1.0	VOLTAGE REGULATOR (REGULATOR / RECTIFIER)	0.2
CRANKCASE COVER	1.2	COOLING FAN	0.3
CRANKCASE COVER GASKET	0.8	COOLING FAN HOUSING	0.2
OIL FILTER (CARTRIDGE) OR OIL DRAIN PLUG	0.1	UPPER ENGINE SHROUD	0.2
OIL PUMP	1.1	LOWER ENGINE SHROUD	0.2
OIL PRESSURE RELIEF VALVE	1.0	STARTER MOTOR ASSY	0.3
OIL FILTER SCREEN (INTERNAL)	0.9	STARTER BRUSH(ES) (Includes Starter (R&R))	0.5
OIL DRAIN PLUG OR GASKET, OR OIL FILLER/OIL LEVEL DIPSTICK TUBE	0.1		
OIL PRESSURE SWITCH	0.2		
<u>PISTON & CRANKSHAFT</u>			
PISTON OR RING SET (1 CYL)	2.1		
PISTON OR RING SETS (ALL)	2.9		
CRANKSHAFT	3.3		
CONNECTING ROD (1 CYL)	2.1		
CONNECTING RODS (ALL)	2.9		
CRANK / OR CAMSHAFT OIL SEAL (PTO SIDE)	0.9		
CRANK / CAMSHAFT OIL SEAL (FLYWHEEL SIDE)	0.8		

