

Circular High Speed Hand Dryer

Operating Instructions and Parts Manual



Model No :

HD0983-17 - WHITE	110-120Vac	HD0984-16 - BLACK	208-240Vac
HD0983-08 - PLATINUM	110-120Vac	HD0985-17 - WHITE	277Vac
HD0983-16 - BLACK	110-120Vac	HD0985-08 - PLATINUM	277Vac
HD0984-17 - WHITE	208-240Vac	HD0985-16 - BLACK	277Vac
HD0984-08 - PLATINUM	208-240Vac		

Please carefully read through this manual before using the product. Observing all safety information, warnings and cautions will protect Yourself and others. Please keep instructions for future reference.

Specifications

Unit Size: mm (Inch)

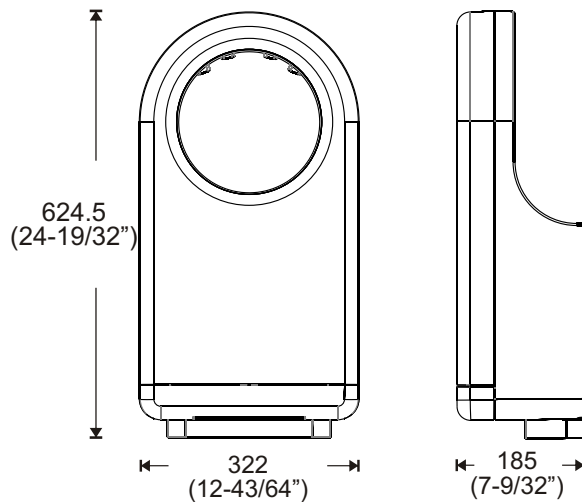

TECHNICAL SPECIFICATIONS

ITEM CATEGORY

PERFORMANCE DATA

Operating Voltage	110-120Vac, 50/60 Hz, 12.2-13.3A, 1.3-1.6 kW 208-240Vac, 50/60 Hz, 5.7-6.6A, 1.2-1.6 kW 277Vac, 50/60 Hz, 6.6A, 1.6 kW
Warm Air Speed Output	65-100 m/s (140-224 mi/hr), Adjustable
Air Output Temperature	60°C (140°F) – Ambient Temp. 20°C (68°F)
Dryer Shall Deliver	89-144 m ³ /h (55-88 CFM)
Cover Type	3,0 mm (1/8") thick molded ABS plastic
Motor Type	1HP, 350-700W, 11000-20000 R.P.M., Adjustable
Motor Thermal Protection	Auto Resetting Thermostat turns unit off, 120V at 135°C (275°F), 240V/ 277V at 95°C (221°F)
Heater Element	ON/ OFF Heating options 450-900W, Adjustable
Heater Thermal Protection	Auto Resetting Thermostat turns unit off at 85°C (185°F) Thermal cut-off at 142°C (288°F)
Standby Power	Less than 0.5W
LED Color	Standby: Red; Active: Blue
Drying Time	10-15 seconds
Circuit Operation	Infrared Automatic, self adjusting
Sensor Range	standard 14 cm ± 2 cm
Sound Pressure	MIN 65 dB-A to 78 dB-A MAX @ 1m
Timing Protection	60 seconds auto shut off
Timing Duration	1 second delayed turn off after last sensor read
Drip proof	IP23
Isolation	CLASS 1
Net Weight	10.8 kg (23.8 lbs)
Shipping Weight	12.8 kg (28.2 lbs)
Unit Size	322 mm (W) x 624.5 mm (H) x 185 mm (D) [12-43/64" (W) x 24-19/32" (H) x 7-9/32" (D)]

Recommended Mounting Heights

<u>DIM'S</u> mm(inch)	A From Top of Hand Drying Chamber	B From Datum Point	C From Bottom of Dryer
Men	1219 (48")	750 (29-17/32")	662 (26-1/16")
Women	1143 (45")	674 (26-17/32")	586 (23-5/64")
Children 4-10 years	940 (37")	471 (18-35/64")	383 (9-59/64")
Children 11-16 years	1067 (42")	598 (23-35/64")	510 (15-5/64")
Handicapped	902 (35-1/2")	434 (17-3/32")	346 (13-5/8")

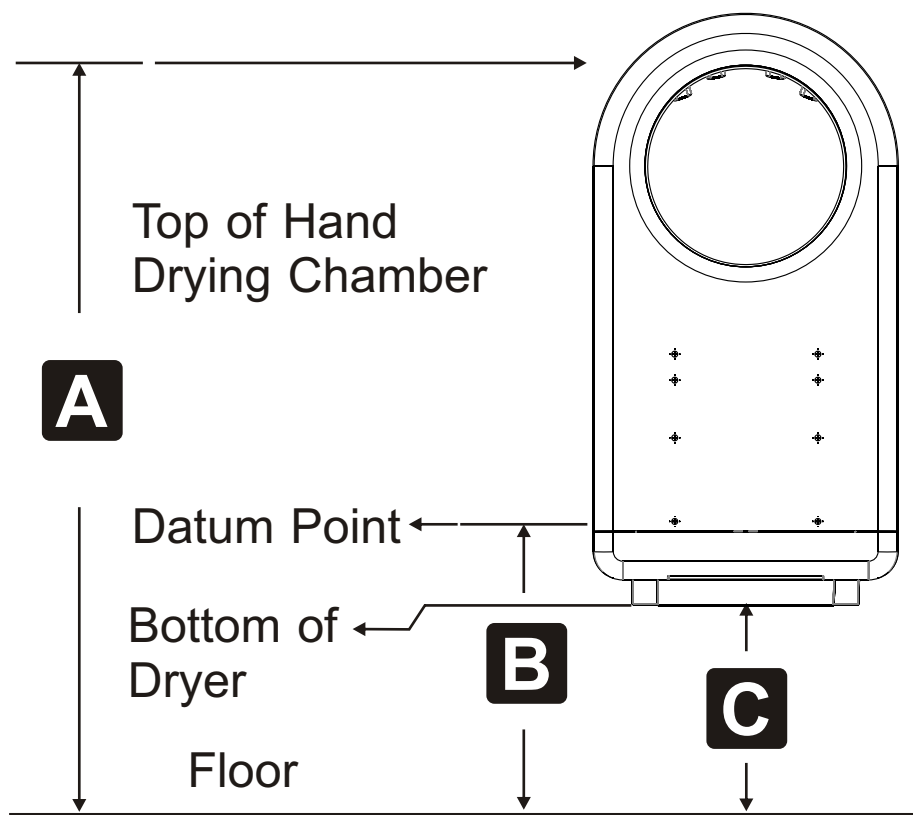

General safety information:

⚠ WARNING *This product is intended for installation by a qualified service person. Select wire ga to suit unit model ratings.*

⚠ DANGER *Failure to properly ground unit could result in severe electrical shock and/or death.*

⚠ WARNING *Disconnect power at the service breaker before installing or servicing.*

⚠ WARNING *All units must be supplied with a 3-wire service. The ground wire must be connected to the dryer's ground terminal.*

Installation Steps

1. Place template against wall at desired height (see mounting height recommendations) and mark locations of eight (8) mounting holes and wire service entry at knockout (KO) location.
2. Use L-Key (supplied) to unlock security hex socket screw and withdraw filter access drawer.
3. a. Drill eight (8) holes at locations marked of $\varnothing 9/32$ " ($\varnothing 7$) x 1-3/8" (35) deep if using wall anchors supplied with unit (fig.1)
b. Remove template and Insert eight (8) plastic anchors (supplied) into drilled holes (fig. 2). Install supplied anchors flush with wall face, or install other fastening system suitable for wall conditions (not supplied).
c. Attach base plate to wall by inserting eight (8) screws (supplied) to fix backplate into plastic anchors (fig. 3). For wood wall/studs use $\varnothing 1/4$ inch (M6) screws at length that will ensure 1 inch (25) min. stud penetration. For masonry walls use expansion bolts or anchors for $\varnothing 1/4$ inch (M6) screws to ensure penetration 1/4 inch (6) deeper than anchor. Shim if necessary to ensure base plate is flat against wall.
4. a. Hang the dryer on the base plate (fig. 4).
b. For Surface Mounted Conduit (exposed) power supply or using power cord (not provided). Provide appropriate conduit to entry location according to local code and attach securely to chassis with correct strain relief connector (not supplied).
c. For in-wall (concealed) power supply - Provide supply wire to KO location according to local code and attach securely to chassis at KO with strain relief connector (supplied).
d. Install locking screw (supplied) into wall plate through the hole at backplate center bottom. (fig. 5)
5. a. Connect hard wired power provided at KO location to terminal block behind cover panel (RH-bottom) behind filter drawer. Turn on circuit breaker to initiate 'stand by- ready to operate' status.

Connections:

- A. Connect the live wire (colored Brown, Red or Black) to the terminal block marked "L".
 - B. Connect the neutral wire (colored Black, Blue, White or Grey) or connect the second live wire (colored Red or Orange) to the terminal block marked "N".
 - C. Connect the ground wire to the terminal block marked " \oplus ". Bare grounding (earth) wires should be sleeved with green and yellow or green tubing. Colors of live and neutral wires depend on voltage of supply service and requirements of Building and Electrical Code having jurisdiction.
- b. Connect power cord to initiate 'stand by- ready to operate' status.
6. Replace the filter access drawer, being careful to not over-tighten the security screw.

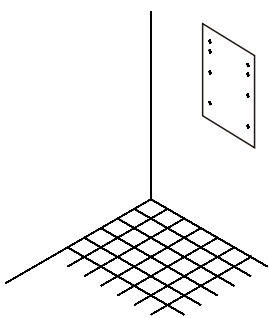

(fig. 1)

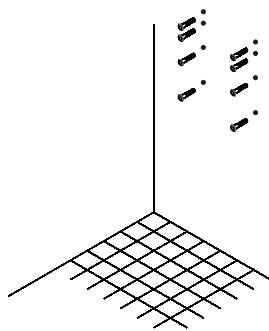

(fig. 2)

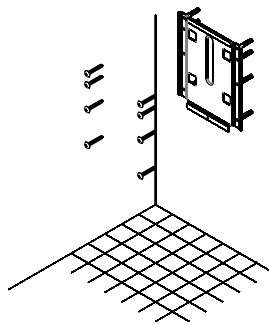

(fig. 3)

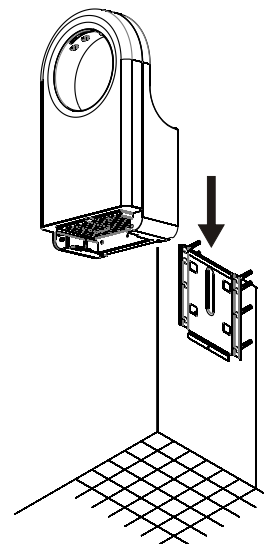

(fig. 4)

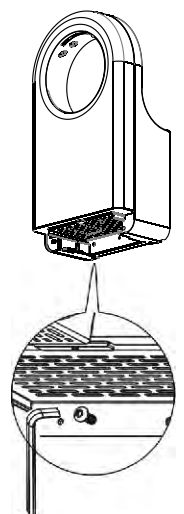

(fig. 5)

Cleaning and Maintenance

Periodic cleaning of the unit is recommended to ensure optimum performance.

- Wipe the cover with a damp cloth and mild cleaning solution.
- Do not Soak, Do not hose down.
- Never use abrasives to clean the cover. Caustic chemicals may damage unit finish.
- No internal parts need any regular cleaning.

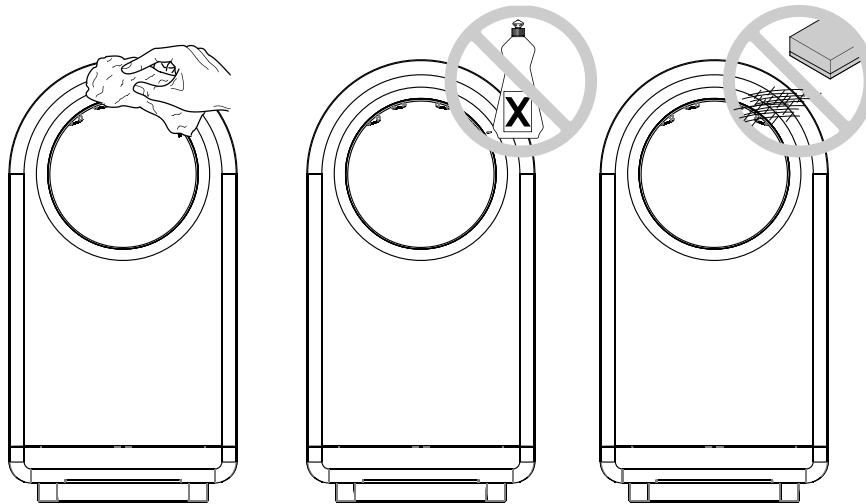

Circuit Diagram

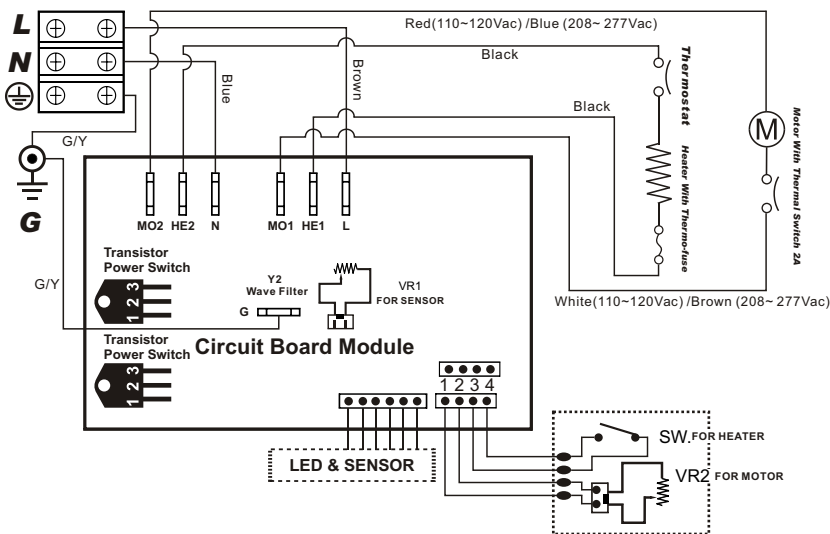

Operation

- 1.** Put your hands through the opening.
- 2.** Dry hands like you wash them.
- 3.** Remove hands and dryer will stop automatically.

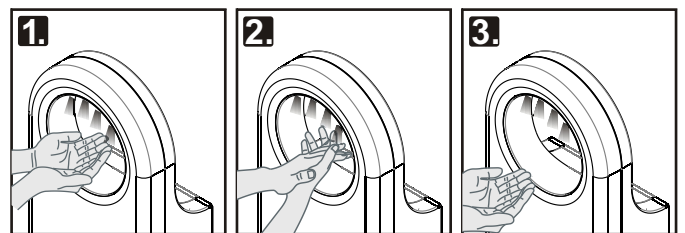

Air Speed Adjustment

It is possible to adjust the speed of the dryer to change the sound level during operation. However, when lowering the motor speed, the drying time will increase.

The usefulness of this function will be dependent on the needs of the owner. The factory setting for dryer's motor speed will be set at its highest speed.

See below for how to adjust the dryer speed:

1. Use Allen key (supplied) to unlock and withdraw the filter access drawer.(fig. 1).
2. Use a small flat blade screwdriver to gently turn adjustment potentiometer(fig. 2) shaft clock-wise [CW] to increase power to maximum (shaft will hard stop; DO NOT OVER TURN!).
3. Turn tool gently CCW to reduce power as required (shaft will hard stop; DO NOT OVER TURN!).
Note that at minimum power the unit may not start if there is low line Voltage.
4. Insert the filter access drawer back into the dryer and lock the security screw.

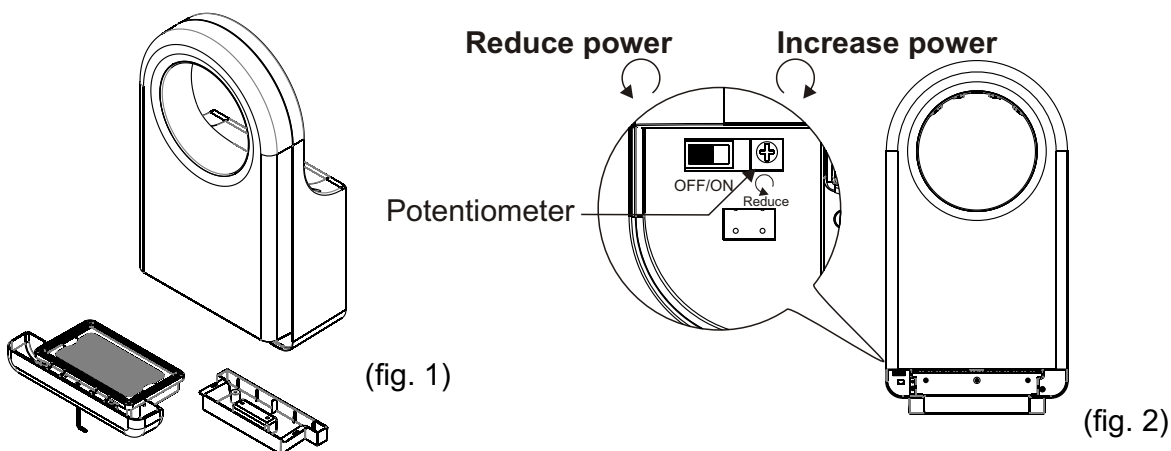

Heater Element Switch ON/ OFF

The dryer has been designed with a heater switch that can turn the heater ON & OFF. The heater switch doesn't affect the drying time. In cold climate location, it may be more comfortable if the heat is on when drying hands. However, it will save a third of the energy used if the switch is off. This function can be adjusted depending on the needs of the owner.

The factory setting for the heater will be on.
See below for how to turn the heater ON/OFF.

1. Use Allen key (supplied) to unlock and withdraw filter access drawer.(fig. 1).
2. Turn the Switch to the right to turn the heater ON. Switch it to the left to turn the heater OFF. (fig. 2)
3. Insert the filter access drawer back into dryer and lock the security screw.

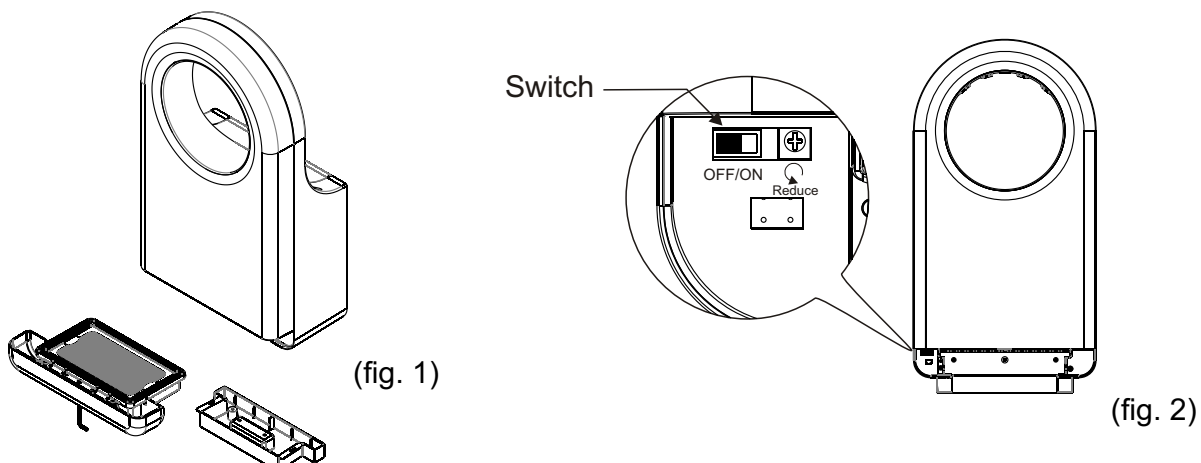

How to Change the SUPER Filter

1. Use Allen key (supplied) to unlock and withdraw filter access drawer.(fig. 1)
2. Change the SUPER filter(fig. 2).
3. Insert the filter access drawer back into the dryer and lock the security screw.

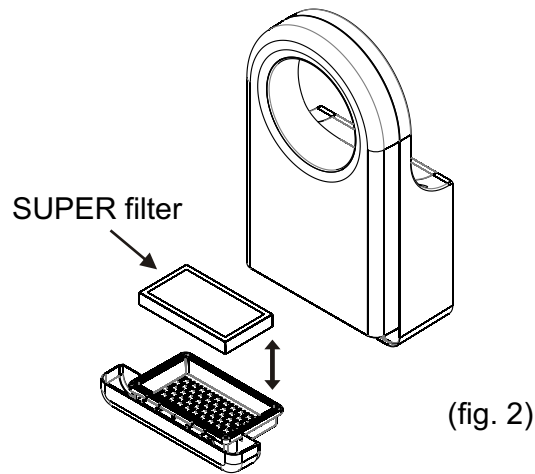
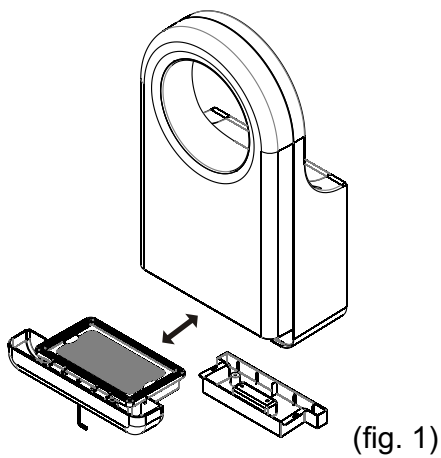

Recommended Period for Changing the SUPER filter

SUPER Filter-

In general use (normal indoor toilets), it's recommended to change the SUPER filter every six (6) months. In dusty and high usage places (factories, outdoor & public toilets), it's recommended to change it every three (3) months.

SUPER filter Assembly Information

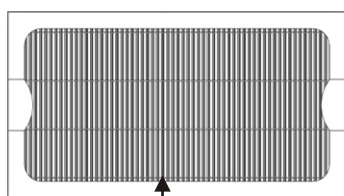

HEPA Filter



Antibacterial Filter

Carbon Filter

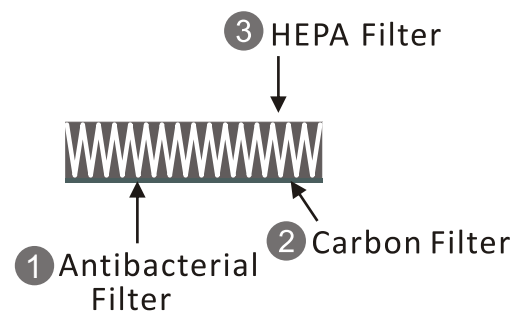

Instructions for use, maintenance and changing the absorbent ceramic

The absorbent ceramic can absorb 70g of water, and has the capacity to take a full load approximately 280 times per day. The ceramic also can evaporate water. During normal use, water will be evaporated continuously and maintain the function of absorbing. The ceramic's ability to absorb water decreases after a long period of use because it gets covered by dust. In this case, please use an abrasive sponge to wipe the surface, and the performance of the function will then return to normal. Improper use or maintenance could result in breakage; see below for replacement instructions.

1. Use the L key to loosen the security screw and remove the drawer. (fig. 1)
2. Use the L key to loosen the security screw of the base plate and remove the machine. (fig. 2)
3. Use a screwdriver to loosen the screw (2 pcs) on the ceramic, and replace it with a new one. (fig. 3)
4. Put the machine back and secure the security screw of the base plate.
5. Put the drawer back and lock up the security screw.
6. It is recommended to replace the ceramic pad every year.

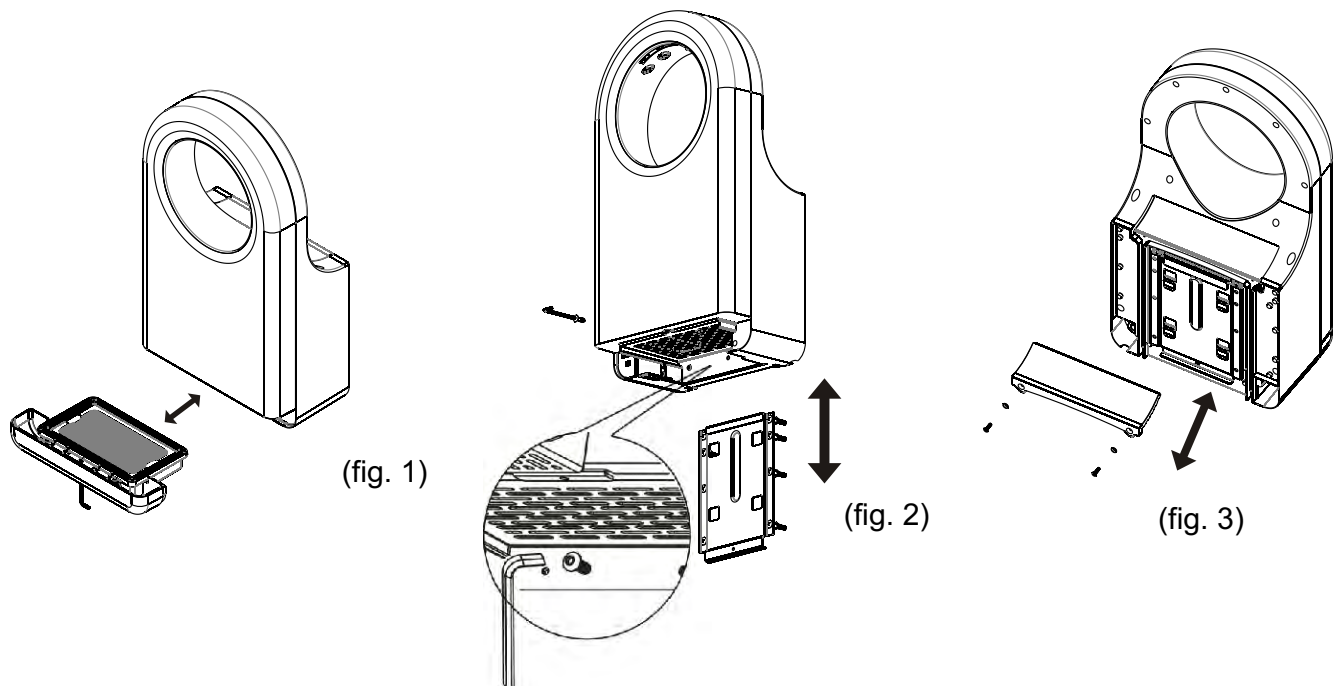

Instructions for use of the drain tank

Generally, the water remaining following usage will evaporate in the absorbent ceramic pad. During high usage periods, leftover water will flow into the drain Tray automatically. The capacity of the drain tray is 240 cc. It's recommended to clean the drain tray every 3 months; water will come through the "overflow hole" if the drain tray is full. A drainpipe (not included) can be added if necessary. The specifications of the drainpipe is I.D. 6mm, O.D. 10mm (fig. 1)

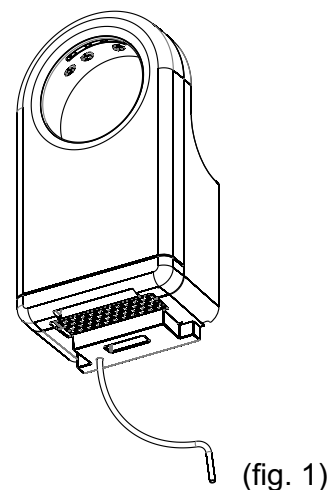

Common First Disassembly Steps

First, Make sure power is OFF before starting step fig. 2. **Second**, Either unplug power cord or disconnect in-wall power connections behind terminal cover prior to starting step fig. 2.

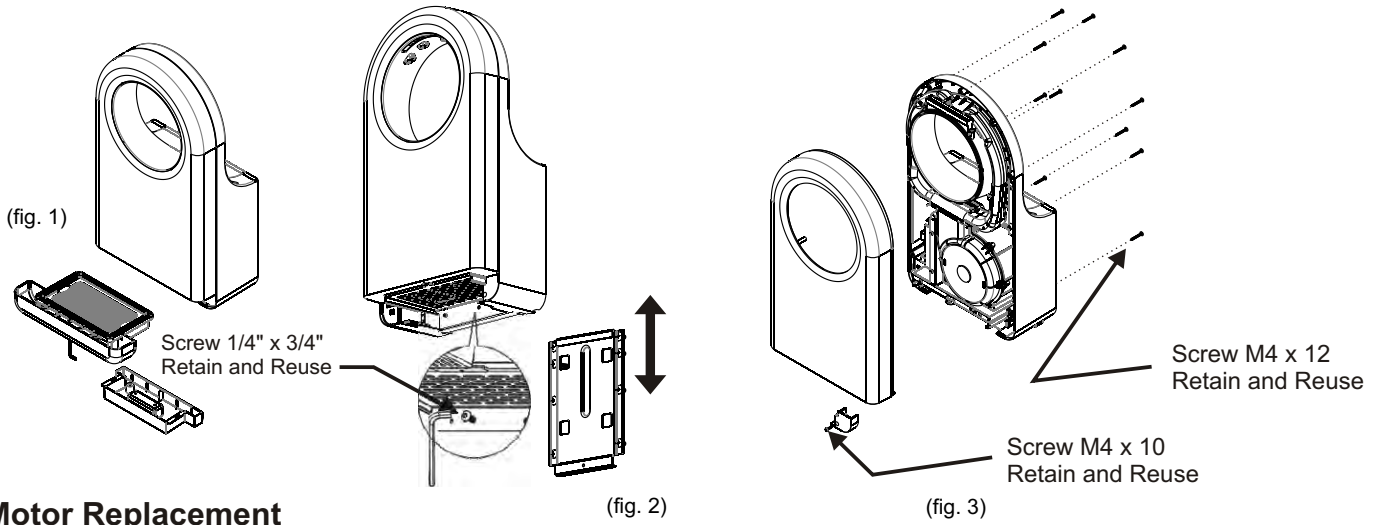

Motor Replacement

Start with steps fig's 1-3

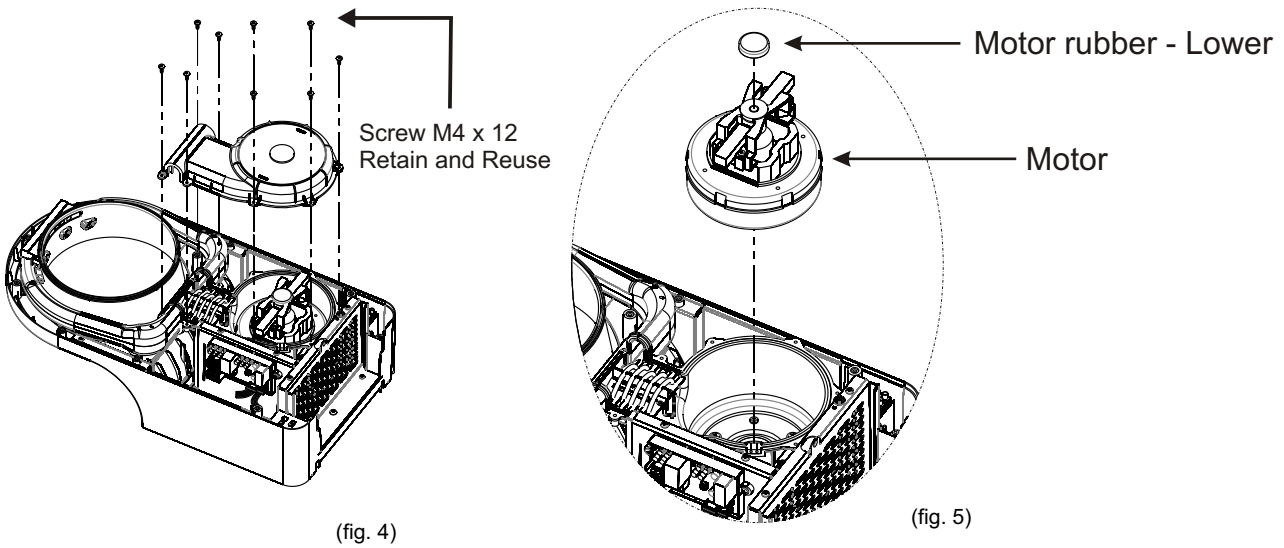

Brush Replacement

Start with steps fig's 1-3. Remove blower housing upper see step fig. 4 under motor replacement.

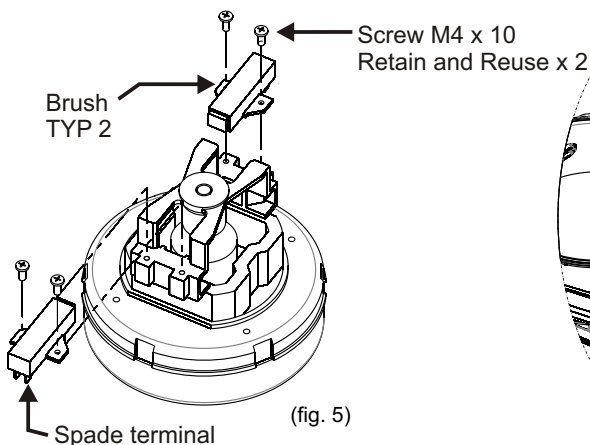

Heater Replacement

Start with steps fig's 1-3. Remove blower housing upper see step fig. 4 under motor replacement.

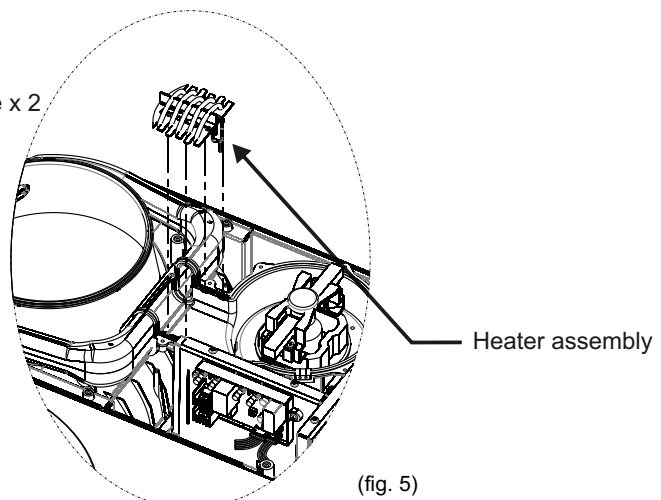

Hand Dryer **Operating Instructions and Parts Manual**

Surface-mounted High-Speed hand dryer

CBM Replacement

Start with steps fig's 1-3

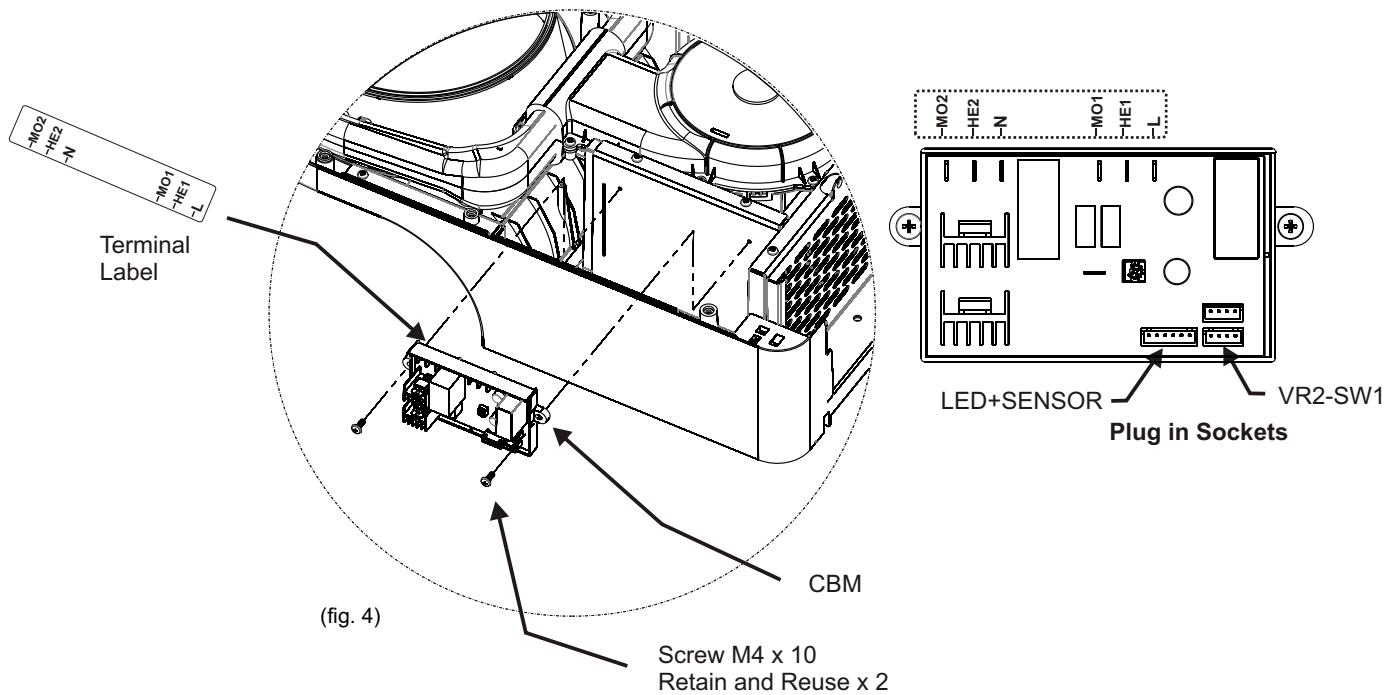

Heater ON/OFF - Speed Control - CBM Replacement

Start with steps fig's 1-3

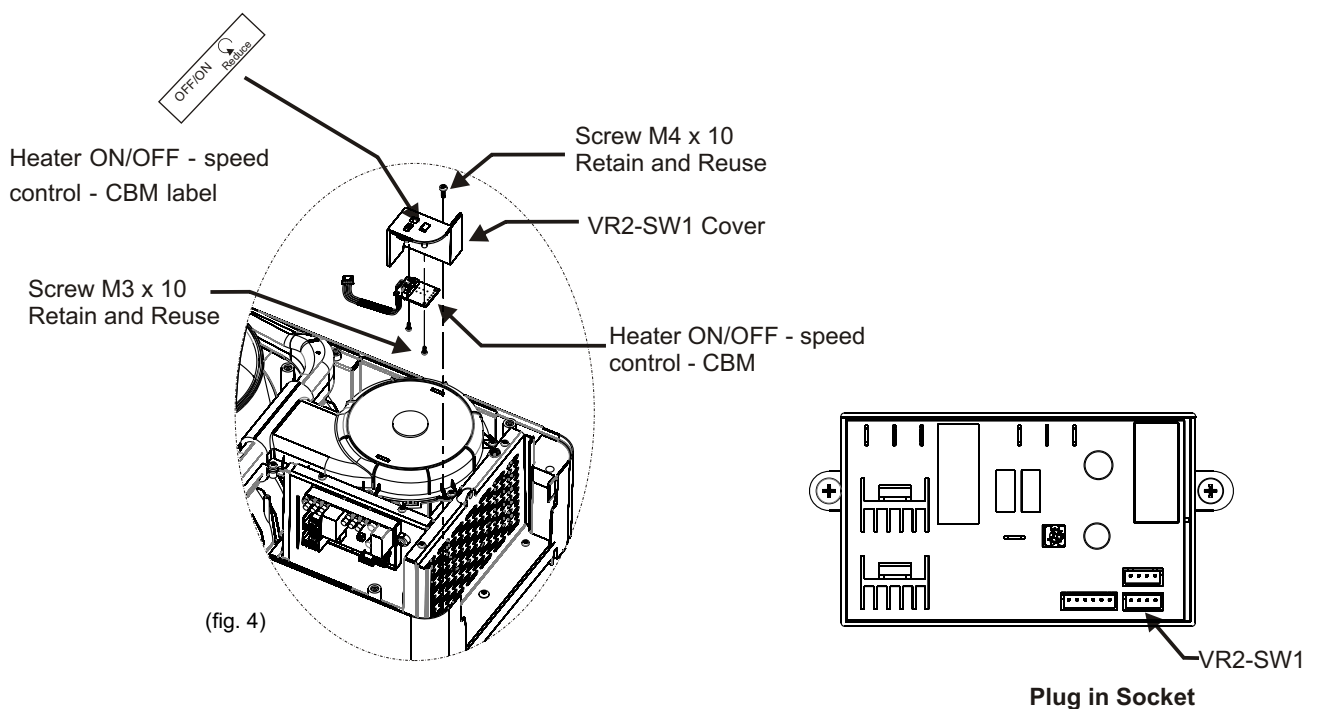

Sensor Module Replacement

Start with steps fig's 1-3

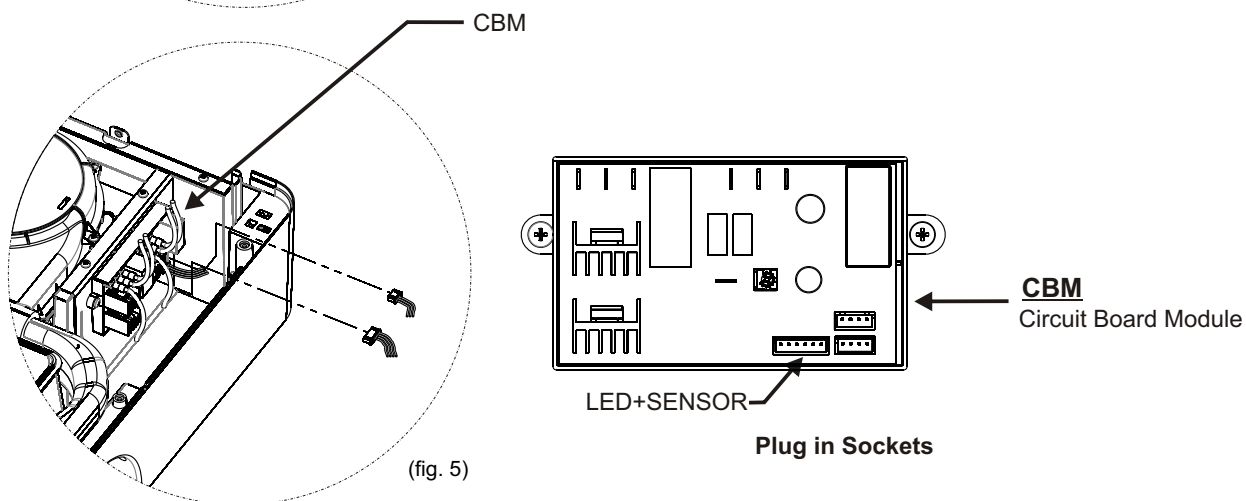
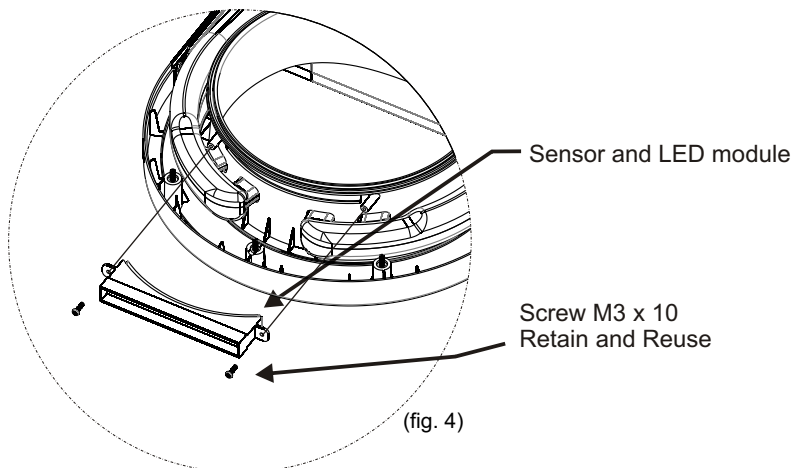

Nozzle Manifold Replacement

Start with steps fig's 1-3. Remove blower housing' upper see step fig. 4 under motor replacement.

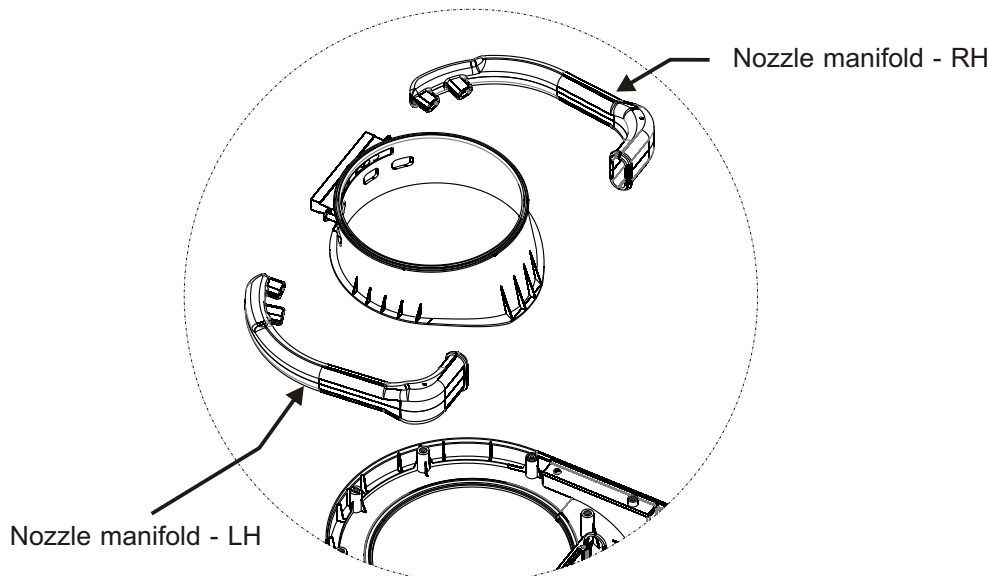

Chamber Replacement

Start with steps fig's 1-3. Remove blower housing' upper
see step fig. 4 under motor replacement.

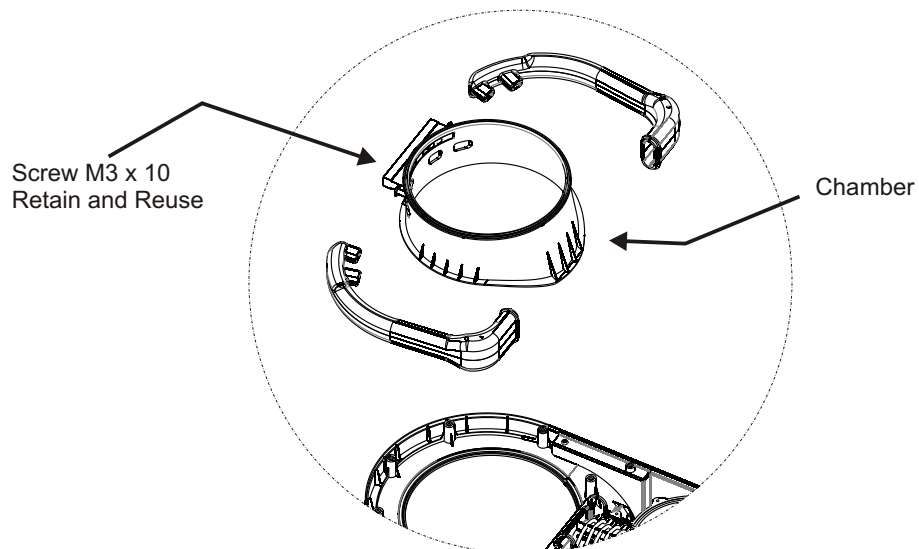

Parts List

Key	Part #	Description	Qty
1	SP098399-0001	Drawer assembly	1
2	SP098399-0002	Super filter assembly	1
3	SP098399-0003	Filter rubber seal	1
4	SP098399-0004	Terminal cover	1
5	SP098399-0005	Cover - front	1
6	SP098399-0006	Blower housing - Upper	1
7	SP098399-0007	Blower housing rubber seal	1
8	SP098399-0008	Motor rubber - Lower	1
9	SP098399-0009	Motor brushes	2
10		Motor	1
	SP098399-0010	1HP@120Vac	
	SP098399-0011	1HP@240Vac	
11	SP098399-0012	Motor rubber cup ring	1
12		Heater assembly	1
	SP098399-0013	900W@120Vac,16Ω	
	SP098399-0014	900W@240Vac,64Ω	
13	SP098399-0015	Blower housing - Lower	1
14	SP098399-0016	Nozzle manifold - RH	1
15	SP098399-0017	Nozzle manifold - LH	1
16	SP098399-0018	Chamber	1
17	SP098399-0019	Sensor and LED module	1
18	SP098399-0020	Bracket - RH	1
19	SP098399-0021	Bracket - LH	1
20	SP098399-0022	Security hex screw	1
21		Circuit Board Module	1
	SP098399-0023	120Vac	
	SP098399-0024	240Vac	
	SP098399-0025	277Vac	
22	SP098399-0026	Air intake screen	1
23	SP098399-0027	CBM bracket	1
24	SP098399-0028	Main bracket	1
25	SP098399-0029	Drain tray	1
26	SP098399-0030	VR2-SW1 cover	1
27	SP098399-0031	Terminal block	1
28	SP098399-0032	Heater ON/OFF - speed control - CBM	1
29	SP098399-0033	Cable holder	1
30	SP098399-0034	Cover - rear	1
31	SP098399-0035	Base plate - wall side	1
32	SP098399-0036	Base plate - cover side	1
33	SP098399-0037	Absorbent ceramic	1
34	SP098399-0038	L-Wrench	1
35	SP098399-0039	C-Wrench	1
36	SP098399-0040	Crimp-on wire tips for terminal block	1
37	SP098399-0041	Power cord (not provided)	1

Assembly Diagram

Service Tool Included (with installation kit)

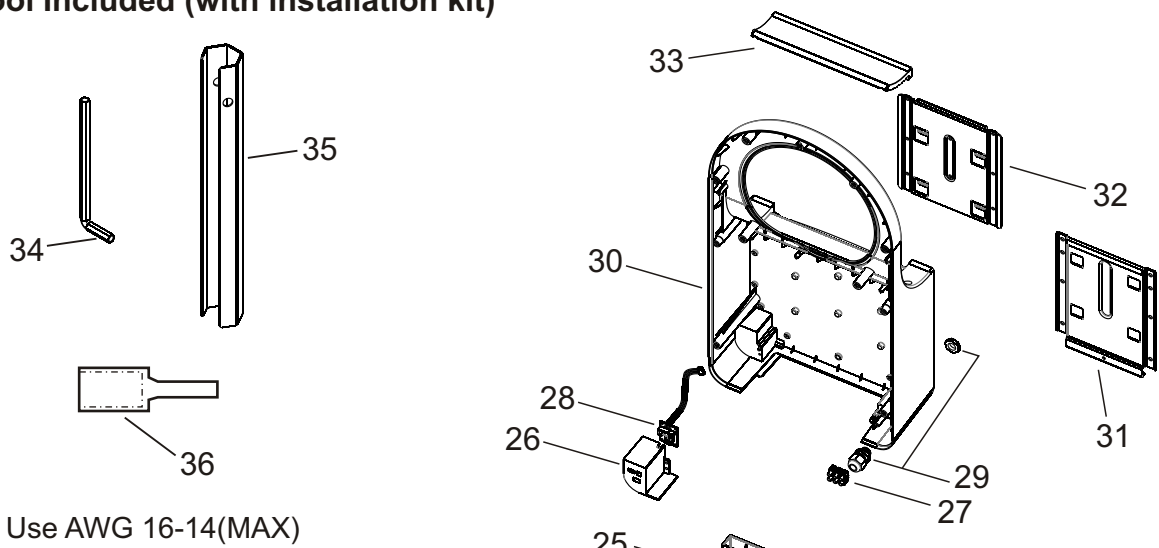

Use AWG 16-14(MAX)

Installation Kit Included (find in carton)

1. Self-Threading pan head screws-
№10 x 1-1/4" (M5 x 32) x 8 pcs
2. Plastic expansion anchor-
Ø9/32" x 1-3/8" (Ø7 x 35) x 8 pcs

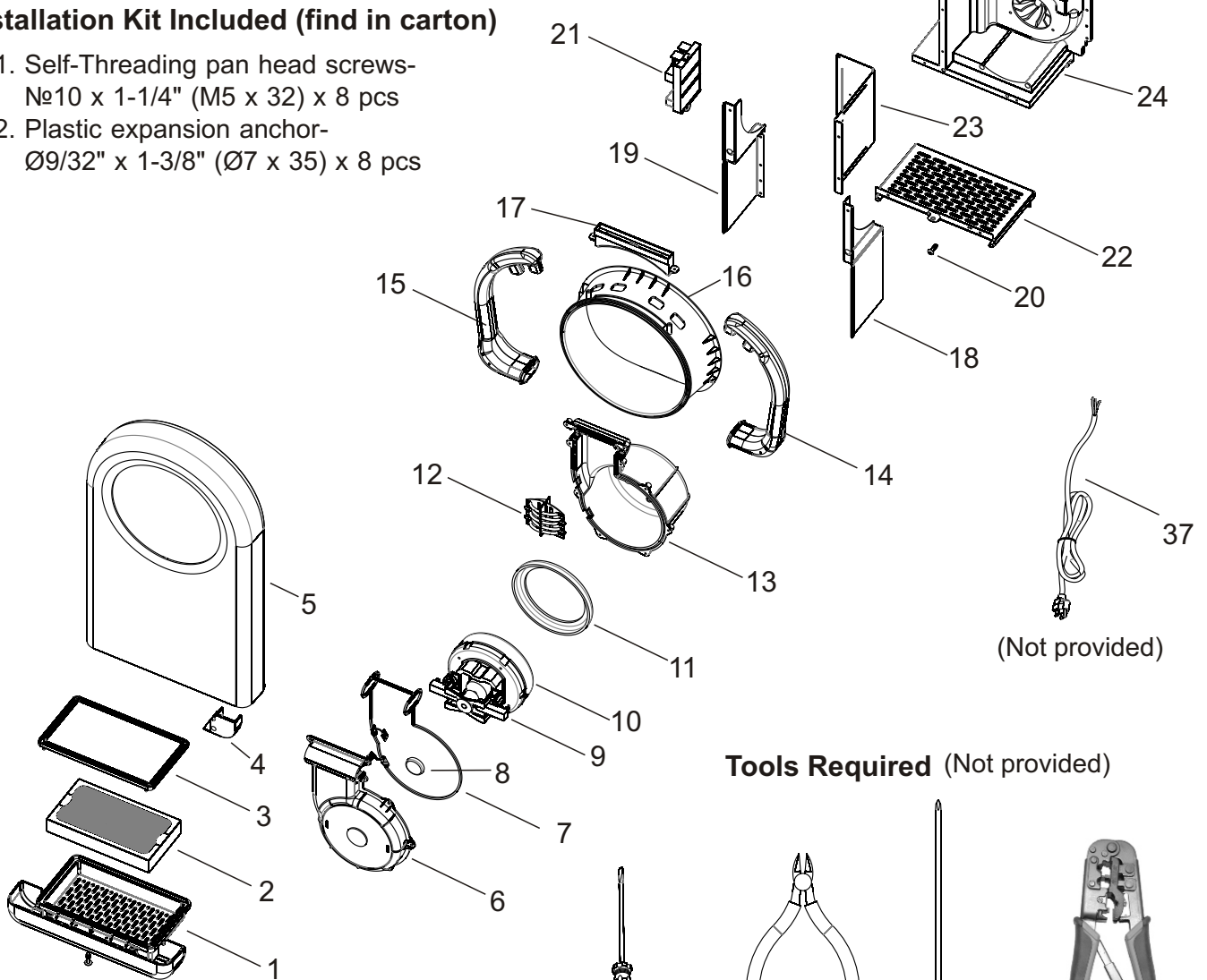

(Not provided)

Tools Required (Not provided)

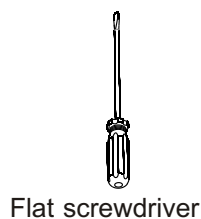

Flat screwdriver

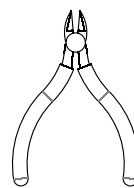

Wire cutter

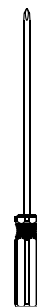

Philips #1/ #2



Crimp tool